

# Heavy Vehicle Local Road Report Clyde



<b>Project Name:</b>	Sydney Metro West		
<b>Client Name:</b>	Sydney Metro		
<b>Project Address:</b>	Delta will be working at the following sites: 1. Parramatta 2. Clyde 3. Westmead		
<b>Project Description/Scope:</b>	DELTA Pty Ltd (DELTA) is responsible for the demolition of existing structures including removal of all hazardous materials and utility works of the Sydney Metro West Project at Clyde, Parramatta and Westmead		
<b>Prepared By:</b>	Name: [Redacted]	Signature: [Redacted]	Date: 12 <sup>th</sup> October 2021
<b>Reviewed By:</b>	Name: [Redacted]	Signature: [Redacted]	Date: 12 <sup>th</sup> October 2021
<b>Authorised By (Project Director):</b>	Name: [Redacted]	Signature: [Redacted]	Date: 12 <sup>th</sup> October 2021

# CONTENTS

Contents .....	2
1 GLOSSARY/ ABBREVIATIONS .....	3
2 AUTHORISATION AND CONTROL.....	4
2.1 Authorisation .....	4
2.2 Distribution .....	4
2.3 Revision .....	4
3 EXECUTIVE SUMMARY.....	5
4 INTRODUCTION .....	6
4.1 Background .....	6
4.2 Purpose .....	7
4.3 Scope.....	7
4.3.1 <i>Minister’s Conditions of Approval and Revised Environmental Mitigation Measures</i> .....	7
4.4 Objectives .....	7
5 LEGAL AND OTHER REQUIREMENTS .....	11
5.1 Legislation .....	11
5.2 Guidelines and Other Documents.....	11
6 EXISTING ENVIRONMENT .....	12
6.1 Locality .....	12
6.1.1 <i>Wentworth Street</i> .....	13
6.1.2 <i>Kay Street</i> .....	17
6.1.3 <i>Unwin Street</i> .....	17
6.1.4 <i>Shirley Street</i> .....	18
6.2 Land use .....	19
6.3 Performance Based Standard Network .....	20
7 PROJECT WORKS.....	21
7.1 Construction vehicles and plant.....	21
7.1.1 <i>Typical movements</i> .....	21
7.1.2 <i>Known sensitive receivers</i> .....	23
8 FLEET MANAGEMENT.....	24
8.1 EIS Haulage routes .....	24
8.2 Proposed heavy vehicle routes and management.....	25
8.2.1 <i>Site management</i> .....	25
8.2.2 <i>Road dilapidation report</i> .....	28
8.3 Cumulative impacts.....	28
8.3.1 <i>Traffic Control Group (TCG)</i> .....	28
8.3.2 <i>Traffic and Transport Liaison Group (TTLG)</i> .....	28
9 SAFETY .....	29
10 CONSULTATION AND COMMUNICATION.....	30
10.1 Stakeholders consulted.....	30
10.2 Induction.....	31
10.3 Toolbox talks.....	31
APPENDICES.....	32
A. Received comments.....	32
B. Swept path analysis .....	33
C. Written advice.....	34
D. Road Dilapidation Report Transmittal .....	35

## 1 GLOSSARY/ ABBREVIATIONS

Term/ abbreviation	Definition
CoPC	City of Parramatta Council
CJP	Customer Journey Planning
CPAS	Construction Parking and Access Strategy
CTMF	Construction Traffic Management Framework (by TfNSW)
CTMP	Construction Traffic Management Plan (site specific)
Local road	Any road that is not defined as a classified road under the <i>Roads Act 1993</i> (NSW)
MCoA	Ministerial Conditions of Approval
REMM	Revised Environmental Management Measure(s)
ROL	Road Occupancy License
Sensitive land use(s)	Includes residences, educational institutions, (including preschools, schools, universities, TAFE colleges), health care facilities, (including nursing homes and hospitals), religious facilities (including churches), child care centres and passive recreation areas (including outdoor ground used for teaching). Receivers that may be considered to be sensitive include commercial premises (including film and television studios, research facilities, entertainment spaces, temporary accommodation such as caravan parks and camping grounds, restaurants, office premises and retail spaces) and industrial premises as identified by the Planning Secretary.
TCG	Traffic Control Group
TCP	Traffic Control Plan – superseded by TGS
TfNSW	Transport for NSW
TGS	Traffic Guidance Scheme (formerly TCP)
TTLG	Traffic and Transport Liaison Group

## 2 AUTHORISATION AND CONTROL

### 2.1 Authorisation

This Plan is authorised by the Project Director. All project personnel are to ensure that their work activities and those of Project Consultants, Contractors and Suppliers are carried out in accordance with the requirements of this Plan.

### 2.2 Distribution

This Plan is a Controlled Document and must be distributed and revised under the guidance of the Project Manager. People who hold Controlled copies are responsible for maintaining their copies up-to-date.

### 2.3 Revision

The Project Director will monitor the implementation of this Plan and review the need for change or improvements having due regard to:

- Change in work scope, client comments etc.
- Internal and external audits
- Suggestions and comments from project personnel
- Incidence and frequency of non-conformance
- Necessity for corrective or preventative action
- Legal Update and Requirements
- Review by Delta Groups Management team
- Annual Review

All changes must be formally approved by the Project Director. Changes to the recent revision will be highlighted.

The following table provides a record of amendments made to this document.

<i>Rev</i>	<i>Date</i>	<i>Description</i>	<i>Page</i>	<i>Developed By</i>	<i>Approved By</i>
0	25/08/2021	Initial Submission	All	[REDACTED]	[REDACTED]
1	17/09/2021	Revised document based on comments received	All	[REDACTED]	[REDACTED]
2	1/10/2021	Revised document based on comments received 29 Sept 21 from Sydney Metro and DPIE comments	All	[REDACTED]	[REDACTED]
3	5/10/2021	Revised to include comments from Sydney Metro	All	[REDACTED]	[REDACTED]
4	12/10/2021	Revised to include comments from Sydney Metro	All	[REDACTED]	[REDACTED]
<i>Distribution Register</i>					
<i>Rev No.</i>	<i>Date of Issue</i>	<i>Name of Recipient</i>	<i>Position / Organisation</i>		
0	25/08/2021	[REDACTED]	Principal's Representative Project Manager		
1	17/09/2021	[REDACTED]	Principal's Representative Project Manager		
2	1/10/2021	[REDACTED]	<i>Principal's Representative Project Manager</i>		
3	5/10/2021	[REDACTED]	<i>Principal's Representative Project Manager</i>		
4	12/10/2021	[REDACTED]	<i>Principal's Representative Project Manager</i>		



### 3 EXECUTIVE SUMMARY

This Heavy Vehicle Local Road report (HVLR) has been developed to address the requirements of the Ministerial Conditions of Approval related to the Critical State Significant Infrastructure of Sydney Metro West.

The HVLR identifies the heavy vehicle routes into the site not identified in the Environmental Impact Statement, the road classification and the suitability of the routes based on swept path analysis and adjacent land uses.

For the Clyde site, the routes proposed into site are via Wentworth Street, Kay Street, Unwin Street and Shirley Street which are all local roads under the care and control of the City of Parramatta Council. The suitability of these routes has been assessed based on typical Heavy Vehicle sizes, eg: semi-trailers and truck and dog combination. The swept paths show that all vehicle types, other than the semi-trailer at the intersection of Unwin Street and Shirley Street, operate satisfactorily.

Wentworth Street crosses Martha Street where the M4 shared path cycleway route is located. To ensure that all road users are aware of this shared path crossing, warning signs are proposed to be installed for both drivers and shared path users.

The use of Performance Based Standard vehicles will not be used at this site, although it is noted that the majority of the Clyde industrial estate roads are nominated PBS routes.

No other works are proposed to facilitate the heavy vehicles movements.

## 4 INTRODUCTION

### 4.1 Background

The Sydney Metro is Australia’s biggest public transport program comprising four main packages of works. The Sydney Metro West (SMW) package is a critical part of this overall program extending from Westmead to The Bays site in Rozelle. The package aims to:

- Provide faster more reliable public transport options between greater Parramatta and the Sydney CBD
- Double the existing rail capacity between Parramatta and Sydney CBDs
- Support growing residential and employment zones between Westmead and The Bays and
- Allow for better public transport transfers between rail lines

The project includes:

- Approximately 24-kilometres of twin tunnels between Westmead and the Sydney CBD
- New metro stations at Westmead, Parramatta, Sydney Olympic Park, North Strathfield, Burwood North, Five Dock, The Bays and Sydney CBD
- A turn-up-and-go metro service operating between Westmead and Sydney CBD.
- The approved Stage 1 construction works includes:
  - Tunnel excavation including tunnel support activities between Westmead and The Bays
  - Station excavation for new stations at Westmead, Parramatta, Sydney Olympic Park, North Strathfield, Burwood North, Five Dock and The Bays
  - Shaft excavation for services facilities at Rosehill, Silverwater and between Five Dock and The Bays
  - Civil work for a stabling and maintenance facility at Clyde
  - A concrete segment facility for use during tunnelling located at Clyde
  - Excavation of a tunnel dive structure and associated tunnels at Rosehill to support a connection between the Clyde facility and the mainline metro tunnels.

The proposed Sydney Metro West alignment and the locations of proposed stations and operational ancillary infrastructure are shown in Figure 1 below.

Sydney Metro has engaged DELTA Group to undertake the demolition works at three sites associated with the Sydney Metro West project, specifically at Clyde, Parramatta and Westmead.

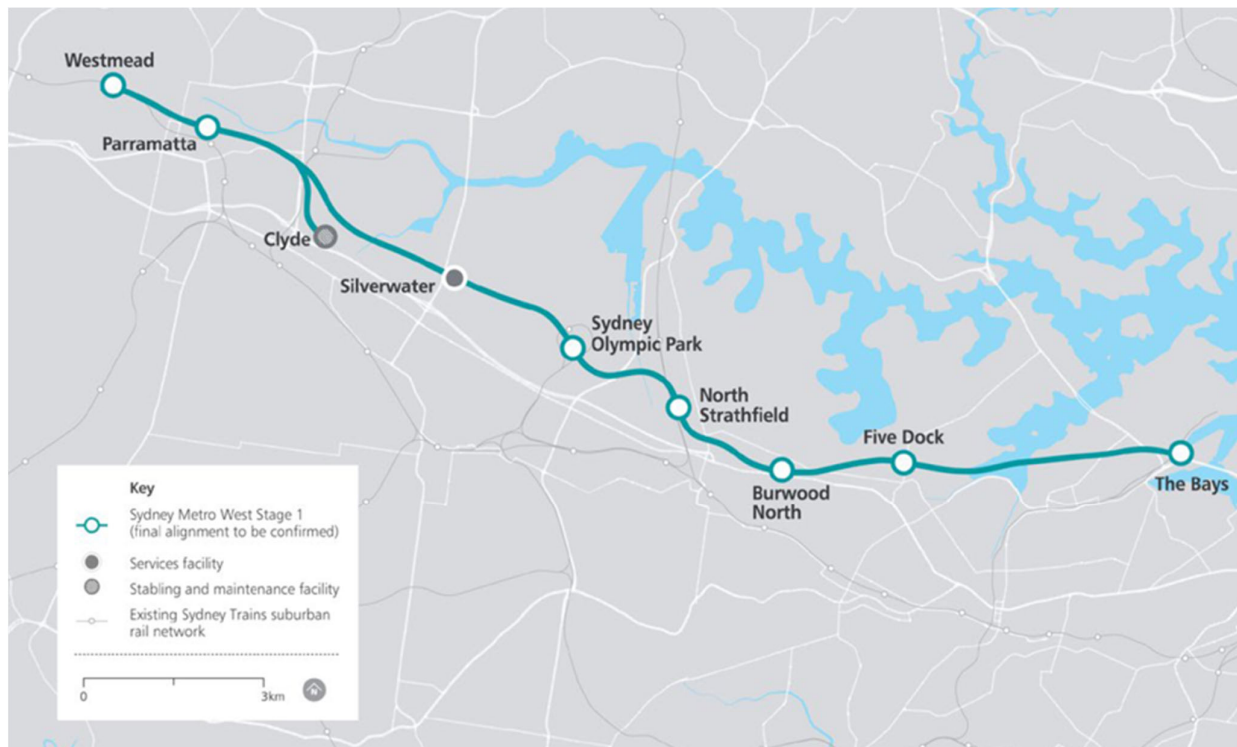

**Figure 1: Sydney Metro West alignment and facilities**

## 4.2 Purpose

The purpose of this document is to define the project requirements for the use of local roads for heavy vehicles (HV) that have not been identified and assessed in:

- Sydney Metro West – Westmead to The Bays and Sydney CBD Environmental Impact Statement dated 15 April 2020
- Sydney Metro West – Westmead to The Bays and Sydney CBD Submissions Report dated 20 November 2020
- Sydney Metro West – Westmead to The Bays and Sydney CBD Amendment Report dated 20 November 2020

This document is used to identify and assesses the HV routes required for the Clyde site for demolition works.

## 4.3 Scope

### 4.3.1 Minister's Conditions of Approval and Revised Environmental Mitigation Measures

DELTA notes that the Project must be carried out generally in accordance with the description provided in the Environmental Impact Statement (EIS) as amended by the Sydney Metro West Westmead to The Bays and Sydney CBD – Amendment Report Concept and Stage 1 2020, and the CSSI Ministerial Conditions of Approval (MCoA) and Revised Environmental Management Measures (REMMs) detailed in Table 1 and Table 2, below

The content of this Heavy Vehicle Local Road (HVLRL) report has been prepared to comply with MCoA D86 and D87 and applies to all works to be undertaken for the demolition works at the Clyde site only. Separate HVLRL reports will be provided for the Parramatta and Westmead sites.

## 4.4 Objectives

DELTA's traffic objectives for the Project are:

- To minimise our impacts on traffic and road users
- To avoid accidents and minimise potential road safety risks
- Minimise changes to the road and path network

**Table 1: Ministerial Conditions of Approval requirements for HVLR**

Requirement	Detail	Where addressed
MCoA D86	Local roads proposed to be used by Heavy Vehicles to directly access construction sites that are not identified in the documents listed in Condition A1 of this scheduled must be approved by the Planning Secretary and be included in the CTMPs	This document
MCoA D87	All requests to the Planning Secretary for approval to use local roads under Condition D86 above must include the following:	Section 7.1
	a) A swept path analysis	Appendix B
	b) Demonstration that the use of local roads by Heavy Vehicles for the CSSI will not compromise the safety of pedestrians and cyclists of the safety of two way traffic flow on two way roadways	Sections 6.1, 8.2, 9 and Appendix B
	c) Details as to the date of completion of the road dilapidation surveys for the subject local roads and	Section 8.2.2
	d) Measures that will be implemented to avoid where practicable the use of local roads past schools, aged care facilities childcare facilities during their peak operation times	Section 7.1.2
	e) Written advice from an appropriately qualified professional on the suitability of the proposed Heavy Vehicle route which takes into consideration items (a) to (d)	Appendix C
MCoA D88	Before any local road is used by a Heavy Vehicle for the purposes of construction of Stage 1 of the CSSI, a Road Dilapidation Report must be prepared for the road. A copy of the Road Dilapidation Report must be provided to the Relevant Road Authority(s) within three (3) weeks of completion of the survey and at no later than one (1) month before the road being used by Heavy Vehicles associated with the construction of Stage 1 of the CSSI	Section 8.2.2

**Table 2: Revised Environmental Management Measures**

Requirement	Impact/ Issue	Mitigation Measure	Where addressed
TT6	Road Safety	All trucks would enter and exit construction sites in a forward direction, where feasible and reasonable	Section <b>Error! Reference source not found.</b>
TT7	Congestion	Construction site traffic would be managed to minimise movements during peak periods	Section 8.2.1
TT8	Congestion	Construction site traffic immediately around construction sites would be managed to minimise vehicle movements through school zones during pick up and drop off times	Section <b>Error! Reference source not found.</b>
TT24	Cumulative construction traffic impacts	<p>Coordination and consultation with the following stakeholders would occur, where required, to manage the interface of projects under construction at the same time:</p> <ul style="list-style-type: none"> <li>Transport for NSW including Transport Coordination</li> <li>Department of Planning, Industry and Environment</li> <li>Sydney Trains</li> <li>NSW Trains</li> <li>Sydney Buses</li> <li>Sydney Water</li> <li>Port Authority of NSW</li> <li>Sydney Motorways Corporation</li> <li>Emergency service providers</li> <li>Utility providers</li> <li>Construction contractors</li> </ul> <p>Coordination and consultation with these stakeholders would include:</p> <ul style="list-style-type: none"> <li>Provision of regular updates to the detailed construction program, construction sites and haul routes</li> </ul>	Sections 8.3 and 10

Requirement	Impact/ Issue	Mitigation Measure	Where addressed
		<ul style="list-style-type: none"> <li>• Identification of key potential conflict pints with other construction projects</li> <li>• Developing mitigation strategies in order to manage conflicts. Depending on the nature of the conflict this could involve:               <ul style="list-style-type: none"> <li>○ Adjustments to the Sydney Metro construction program work activities or haul routes or adjustments to the program activities or haul routes of other construction projects</li> <li>○ Coordination of traffic management arrangements between projects</li> </ul> </li> </ul>	

Note that all other allocated traffic, transport and parking MCoA and REMMs will be managed through the preparation and implementation of the Construction Traffic Management Plans prepared in accordance with MCOA D85, and in line with Sydney Metro's Construction Traffic Management Framework (CTMF) or the Construction Parking and Access Strategy.

## 5 LEGAL AND OTHER REQUIREMENTS

### 5.1 Legislation

Identified regulatory requirements are:

- An approved and valid Road Occupancy Licence (ROL) both Transport Management Centre and City of Parramatta Council
- An approved relevant Speed Zone Authorisation (SZA)
- Approved permits from City of Parramatta including Road Opening Permit (ROP) and Hoarding Permit, where required
  - Australian Road Rules form the basis for state and territory road rules.
  - Roads Act 1993 (NSW) sets out rights along a public road, establishes procedures for a public road and provides the classification of roads.

Legislation relevant to traffic management also includes the *Environmental Planning and Assessment Act 1979* (EP&A Act), under which the project approval was granted.

DELTA regularly reviews its legislative requirements in accordance with its Integrated Management System (IMS).

### 5.2 Guidelines and Other Documents

Guidelines, specifications, and policies relevant to traffic include:

- AUSTRROADS Cycling Aspects of AustRoads Guides, 2017
- AUSTRROADS Guide to Traffic Management, 2020 – Parts 1-13
- AUSTRROADS Guide to Road Design, 2009-2020 – Parts 1-8
- AUSTRROADS Guide to Road Safety, 2006-2019 – Parts 1-9
- AUSTRROADS Road Safety Audit Second Edition, 2019: Checklist 4. Pre-opening scheme audit.
- AUSTRROADS Road Safety Audit Second Edition, 2019: Checklist 5: Roadwork traffic scheme audit.
- AUSTRROADS Road Safety Audit Second Edition, 2019: Checklist 6: Existing roads: road safety audit.
- Department of Infrastructure, Planning and Natural Resources Planning Guidelines for Walking and Cycling (2004)
- Roads & Traffic Authority NSW Guide to Traffic Generating Developments, 2002
- Roads & Traffic Authority NSW Bicycle Guidelines Version 1.2, 2005
- Roads and Maritime QA Specification G10 – Traffic Management, 2020.
- Roads and Maritime NSW Speed Zoning Guidelines, 2011.
- Roads and Maritime Traffic Control at Worksites Manual, 2020



## 6 EXISTING ENVIRONMENT

### 6.1 Locality

The site is located in an industrial area of western Sydney and is bounded by M4 motorway, James Ruse Drive and Rosehill Gardens Racecourse and has street frontage on Unwin Street, Kay Street, Wentworth Street and Shirley Street, Clyde as shown on Figure 2, below.

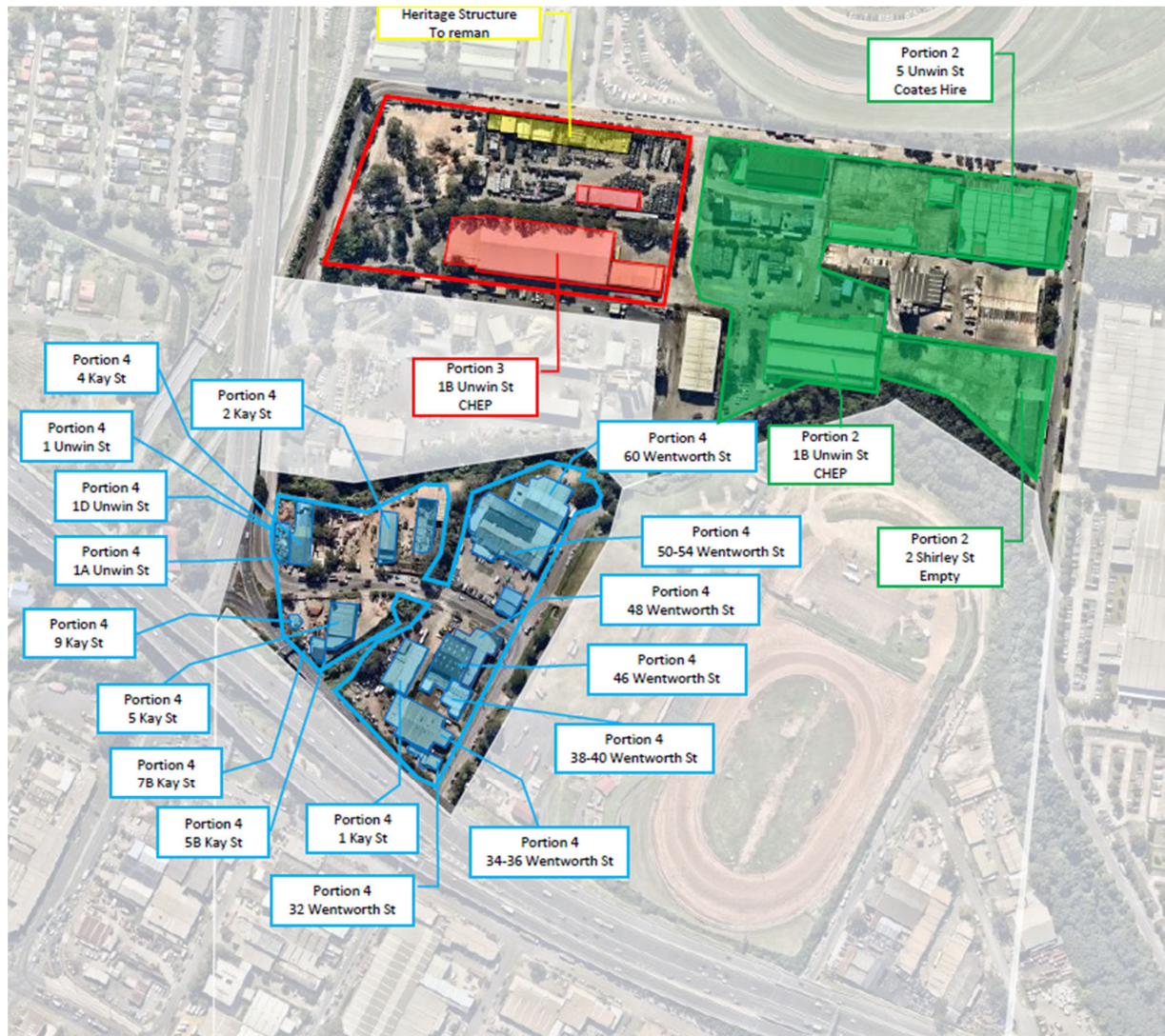
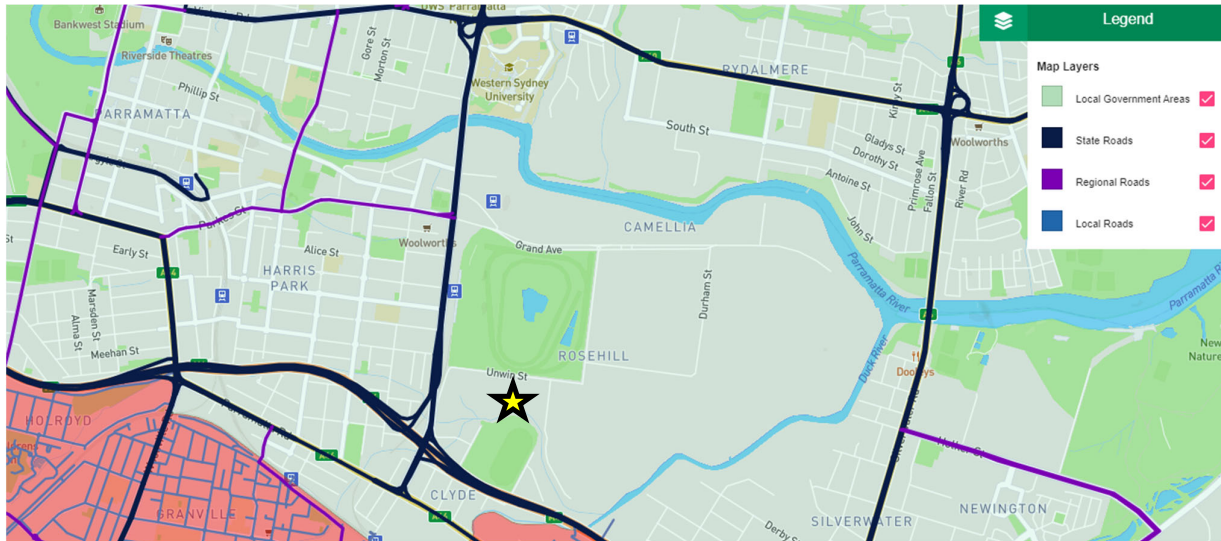

Figure 2: Clyde site location

Access to the M4 motorway inbound carriageway is available from James Ruse Drive. Access to the M4 motorway outbound carriageway is via Great Western Highway/ Parramatta Road and Church Street. As shown on Figure 3 **Error! Reference source not found.**, below, the M4, Great Western Highway, James Ruse Drive, Church Street and the M4 Motorway are State Roads.



**Figure 3: NSW Road Classification** (source: [Road Network Classifications \(nsw.gov.au\)](http://Road Network Classifications (nsw.gov.au)))

**6.1.1 Wentworth Street**

Wentworth Street is a local road under the care and control of the City of Parramatta Council. It commences at Parramatta Road and terminates at A’becketts Creek, Clyde. The speed limit is 50km/hr. This street has substantial industrial land uses with high heavy vehicle use. Wentworth Street is one of the main access/ egress points into the Clyde industrial estate.

Figure 4 provides peak period traffic volumes on Wentworth Street.

**Table 10-16: Clyde stabling and maintenance facility construction site existing traffic volumes (2019)**

Road	Direction	Morning peak hour (vehicles per hour)	Evening peak hour (vehicles per hour)
Unwin Street west of Colquhoun Street	Eastbound	220	190
	Westbound	280	130
Parramatta Road west of Wentworth Street	Eastbound	1,730	1,600
	Westbound	2,110	1,950
Kay Street west of Wentworth Street	Eastbound	150	170
	Westbound	270	90
James Ruse Drive north of Parramatta Road	Eastbound	1,300	1,280
	Westbound	1,500	1,110
Wentworth Street north of Parramatta Road	Eastbound	260	120
	Westbound	150	180

**Figure 4: EIS Chapter 10 Transport and Traffic Stage 1 (page 10-13 Table 10-16)**

Traffic signals exist at its intersection with Parramatta Road allowing all turning movements, by providing a dedicated right turn bay on Parramatta Road for northbound traffic and no restrictions in place on other turn movements. A Left Turn on Red is provided for vehicles egressing from Wentworth Street onto Parramatta Road.



A signalled pedestrian crossing is provided across Wentworth Street at Parramatta Road. This crossing is protected by a red arrow hold for left turning vehicles from Parramatta Road onto Wentworth Street. Footpaths are provided between Great West Highway to Kay Street on the western side. On the eastern side the footpath is discontinued under the M4 overpass, refer to Figure 5.



Figure 5: Existing footpaths and shared paths adjacent to Clyde site

A shared cycle path crosses Wentworth Street at the intersection with Martha Street, refer to Figure 6. No dedicated crossing facilities are provided across Wentworth Street. This shared path is part of the M4 shared path which connects South Wentworthville to the west with Sydney Olympic Park to the east.

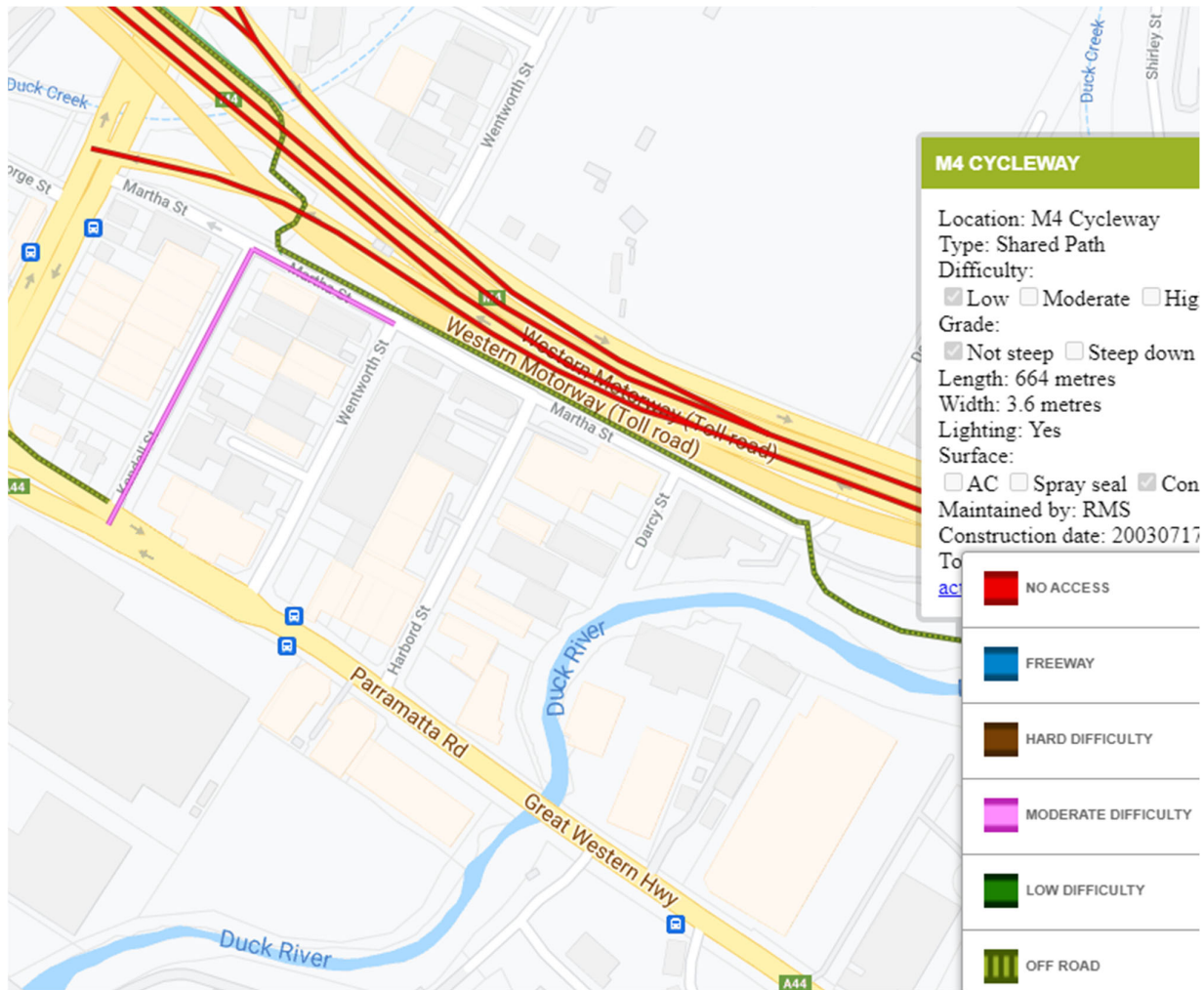

Figure 6: Existing cycle network Clyde

Parking is generally unrestricted along Wentworth Street, with No Stopping provided at intersections and intermittently across existing driveways., refer to Figure 7.



**Figure 7: Parking restrictions adjacent to the Clyde site**

No public transport services operate on Wentworth Street or any streets within the Clyde industrial area. The closest public transport services are on Parramatta Road and Clyde Railway Station, located 1km from Wentworth Street.



**6.1.2 Kay Street**

Kay Street is a local road under the care and control of the City of Parramatta Council. It commences at Wentworth Street and terminates at Unwin Street, Clyde. The speed limit is 50km/hr. Similar to Wentworth Street this street services a highly industrialised area with high heavy vehicle use. At its intersection with Wentworth Street, the priority movement is from Wentworth Street northbound into Kay Street westbound and visa versa. The intersection priority is shown in Figure 8. No other intersections exist along Kay Street. At the western end, Kay Street continues as Unwin Street.



**Figure 8: Kay Street Wentworth Street priority**

Footpaths exist on both sides of the street. The southern footpath is discontinued outside of 7-9 Kay Street property boundary. On the northern side of Kay Street, the footpath continues onto Unwin Street, however, it is in a poor state of repair, refer to Figure 5 and Figure 9 below.



**Figure 9: Kay Street/ Unwin Street footpath**

Similar to Wentworth Street, no public transport services operate. Kay Street also forms part of the PBS road network, refer to Figure 12.

**6.1.3 Unwin Street**

Unwin Street is a local road under the care and control of the City of Parramatta Council. It commences at Kay Street and terminates at Colquhoun Street, Clyde. The speed limit is 50km/hr. Similar to Wentworth and Kay streets, this

street services a highly industrialised area with high heavy vehicle use. On the northern side of Unwin Street, Rosehill Racecourse and associated stables are located. On the southern side of Unwin Street, a number of industrial estates exist.

Parking is as shown on Figure 7, with the majority of Unwin Street between Unwin Street and Shirley Street being unrestricted.

No public transport services operate along Unwin Street. A footpath exists on the eastern side between Kay Street to where Unwin Street (east to west) meets Unwin Street (north-south), refer to Figure 5. No other footpaths exist along Unwin Street. A footpath connection does connect Unwin Street via Fleet Street to James Ruse Drive.

Speed management devices are installed along Unwin Street, as shown on Figure 10.



**Figure 10: Typical speed management devices**

#### **6.1.4 Shirley Street**

Shirley Street is a local road under the care and control of the City of Parramatta Council. It commences at Unwin Street and terminates at Duck Creek, Clyde. The speed limit is 50km/hr. Similar to all other streets in the area, this street services a highly industrialised area with high heavy vehicle use.

Shirley Street is typically unrestricted parking, as noted on Figure 7.

No public transport services operate along Unwin Street. A footpath exists on both sides of Shirley Street for approximately 300m, refer to Figure 5.

As with other roads noted above, Shirley Street forms part of the PBS network, as noted in section 6.3.



## 6.2 Land use

The site is located in a heavy industrialised area of western Sydney, refer to Figure 11. The Rosehill racecourse and stabling yards are located off Unwin Street to the north. Access to the racecourse is also available from Grand Avenue, off James Ruse Drive.

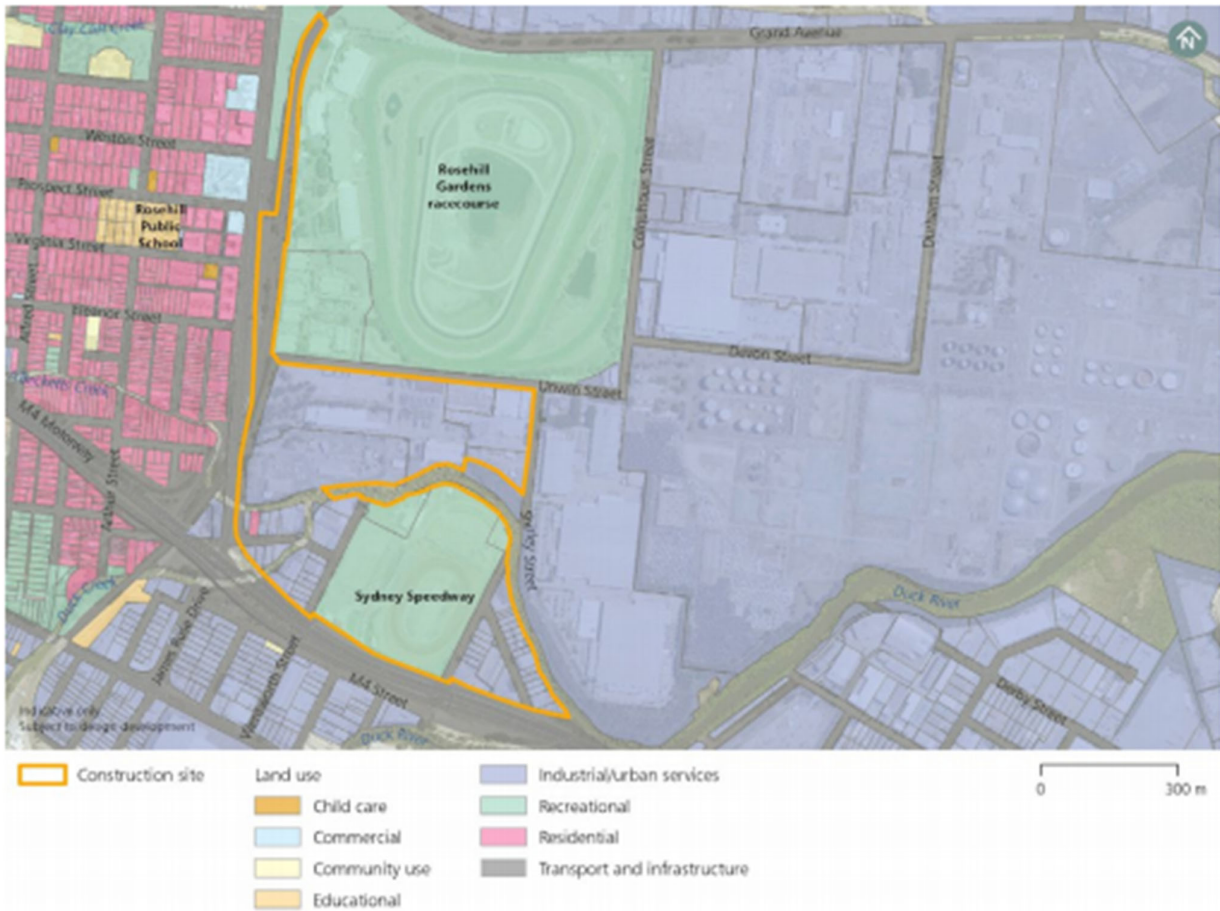

Figure 11: Land use - Clyde (source: Chapter 14 Property and Land Use EIS)

### 6.3 Performance Based Standard Network

Wentworth Street, Kay Street, Unwin Street and Shirley Street form part of the PBS network, as noted on Figure 12, below. However, DELTA can confirm that no PBS vehicles will be used for the works.

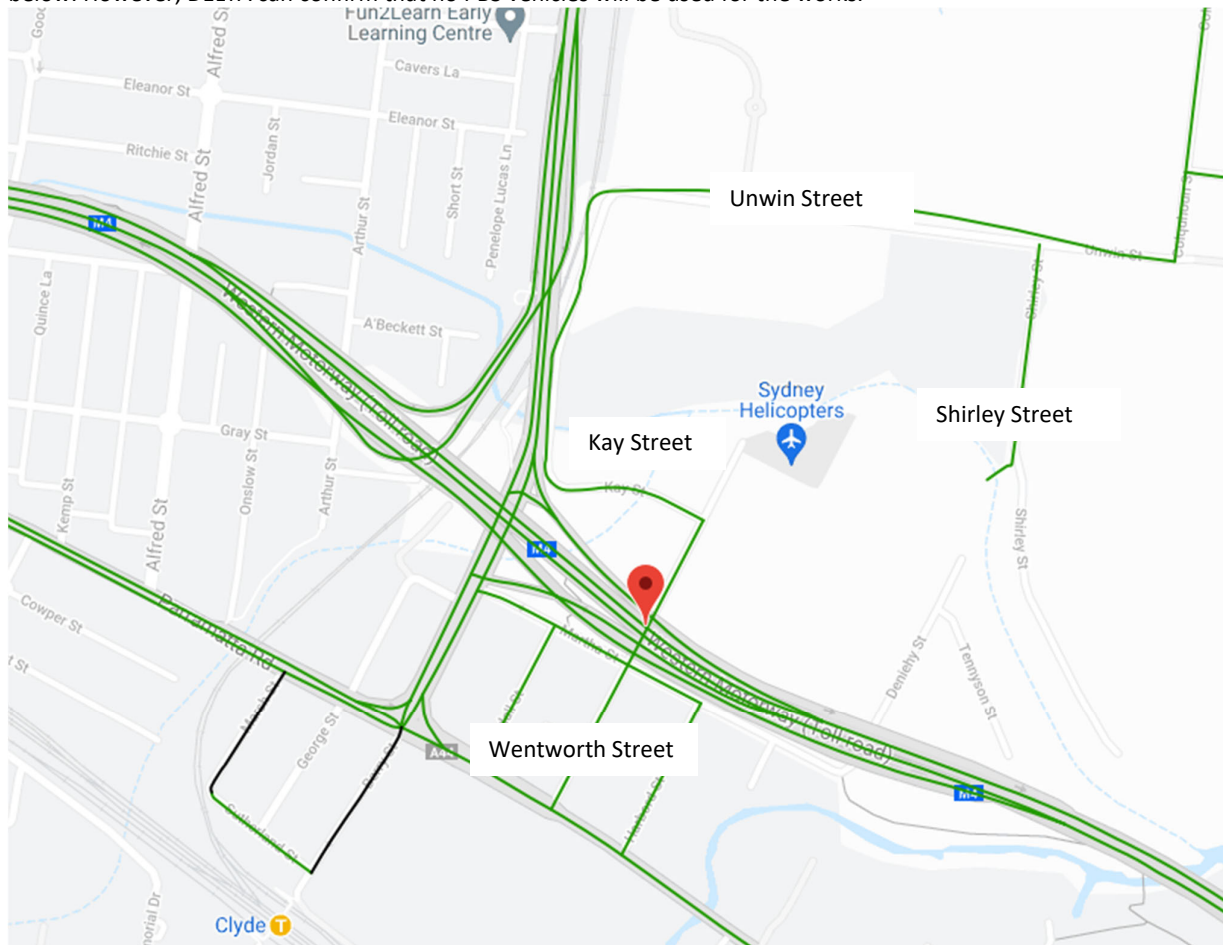

Figure 12: PBS Network (source: [TfNSW PBS](#))

## 7 PROJECT WORKS

The scope of works for the Clyde site is as follows:

- Mobilisation and site set up
- Project planning, approvals and stakeholder management
- Service relocations and decommissioning
- Removal of existing substations
- Demolition of structures

Figure 13 provides the details of the works areas, whilst Table 3 provides the access dates

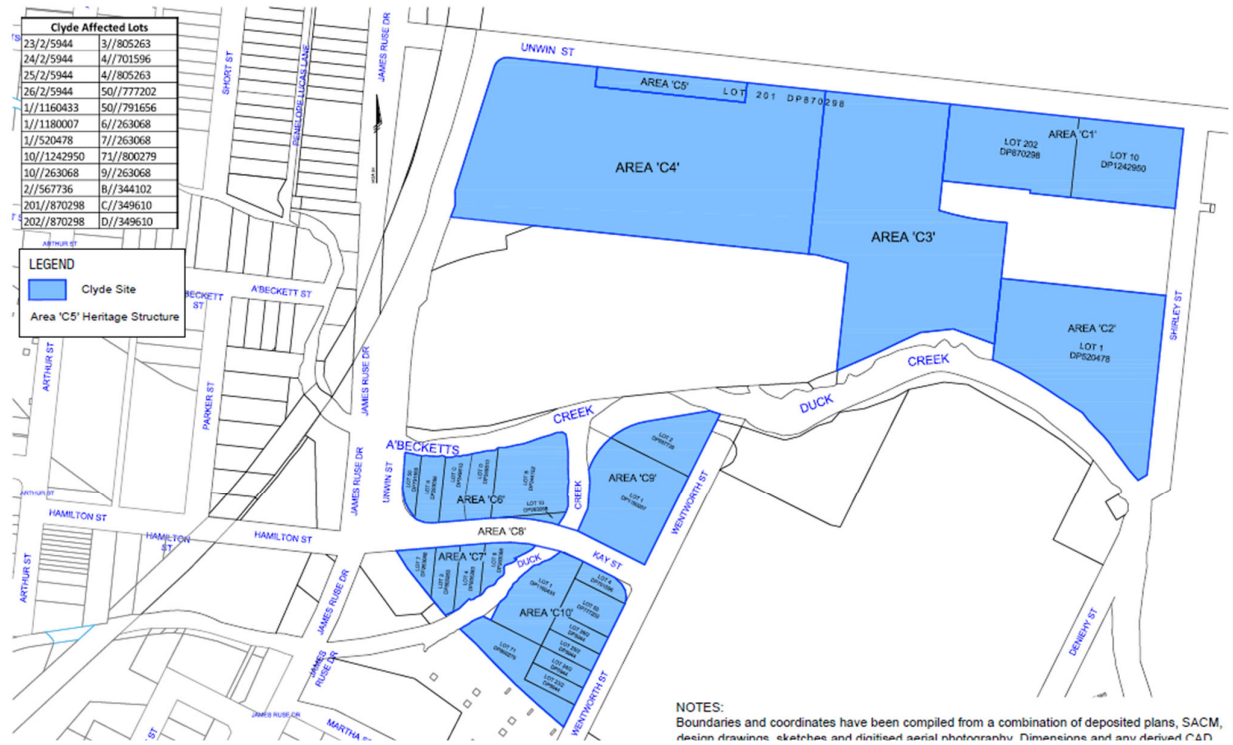

**Figure 13: Areas of work**

**Table 3: Site access schedule**

Area of the site	Location	Site Access Date
Area C1	Unwin Street	21 October 2021
Area C2	Shirley Street, Duck Creek	21 October 2021
Area C3	Unwin Street, Duck Creek	4 January 2022
Area C4	Unwin Street	4 January 2022
Area C5	Unwin Street	4 January 2022
Area C6	Kay Street and Unwin Street	21 October 2021
Area C7	Kay Street and Duck Creek	21 October 2021
Area C9	Wentworth Street, Kay Street and Duck Creek	21 October 2021
Area C10	Wentworth Street, Kay Street, Duck Creek	21 October 2021

### 7.1 Construction vehicles and plant

The project works include demolition and utility works, requiring the use of Heavy Vehicles (HV) and large plant such as:

- Heavy Vehicles – rigid trucks, articulated trucks, crane trucks
- Excavators
- Mobile cranes – articulated and slewing

#### 7.1.1 Typical movements

HV will transport materials from the work sites to authorised disposal sites. The number of vehicles at each site is detailed in Table 4 and the EIS vehicle movements is also provided on Figure 14. The EIS did not allocate heavy vehicle numbers to individual driveways, the EIS looked at overall movement numbers over individual hours of the day.

It is noted that these numbers are significantly less than those previously seen on Wentworth Street, as identified in the previously, refer to Figure 4. It should be further noted that with all businesses now removed due to the demolition works, the number of vehicles in the Clyde area should be significantly lower than previously recorded.

**Table 4: EIS and DELTA proposed HV movements**

Area	Gate	EIS heavy vehicle	DELTA heavy vehicle #	
Area C1	Hytec		20	
Area C2	Coates Hire		6	
Area C3	Tollfast		100	
Area C4 and C5	Hillrose Business Park		50	
Area C6	2 Kay Street		6	
Area C7	1 Kay Street		20	
Area C9	50 Wentworth Street		70	
Area C10	36, 38-40 Wentworth Street		70	
<b>Total per day</b>			<b>352</b>	<b>342</b>

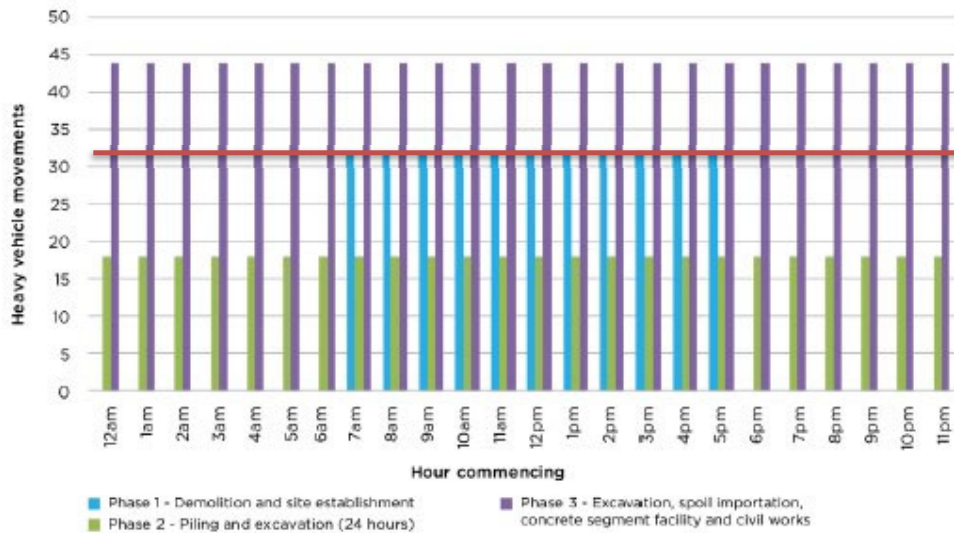

**Figure 10-14: Hourly heavy vehicle movements at the Clyde stabiling and maintenance facility construction site**

*Note: Movement means a one way movement. A truck entering and then leaving a work site represents 2 movements.*

**Figure 14: EIS heavy vehicle movements**



**7.1.2 Known sensitive receivers**

A review of the existing sensitive receivers and their locations was undertaken by Sydney Metro during the EIS development phase of the project, with the results as noted on Figure 15 from the EIS. This review noted no schools or aged care facilities within the vicinity of the Clyde site and along the routes nominated in Table 5. It is noted that the Australian Turf Club (ATC) Rosehill Racecourse is a sensitive receiver.

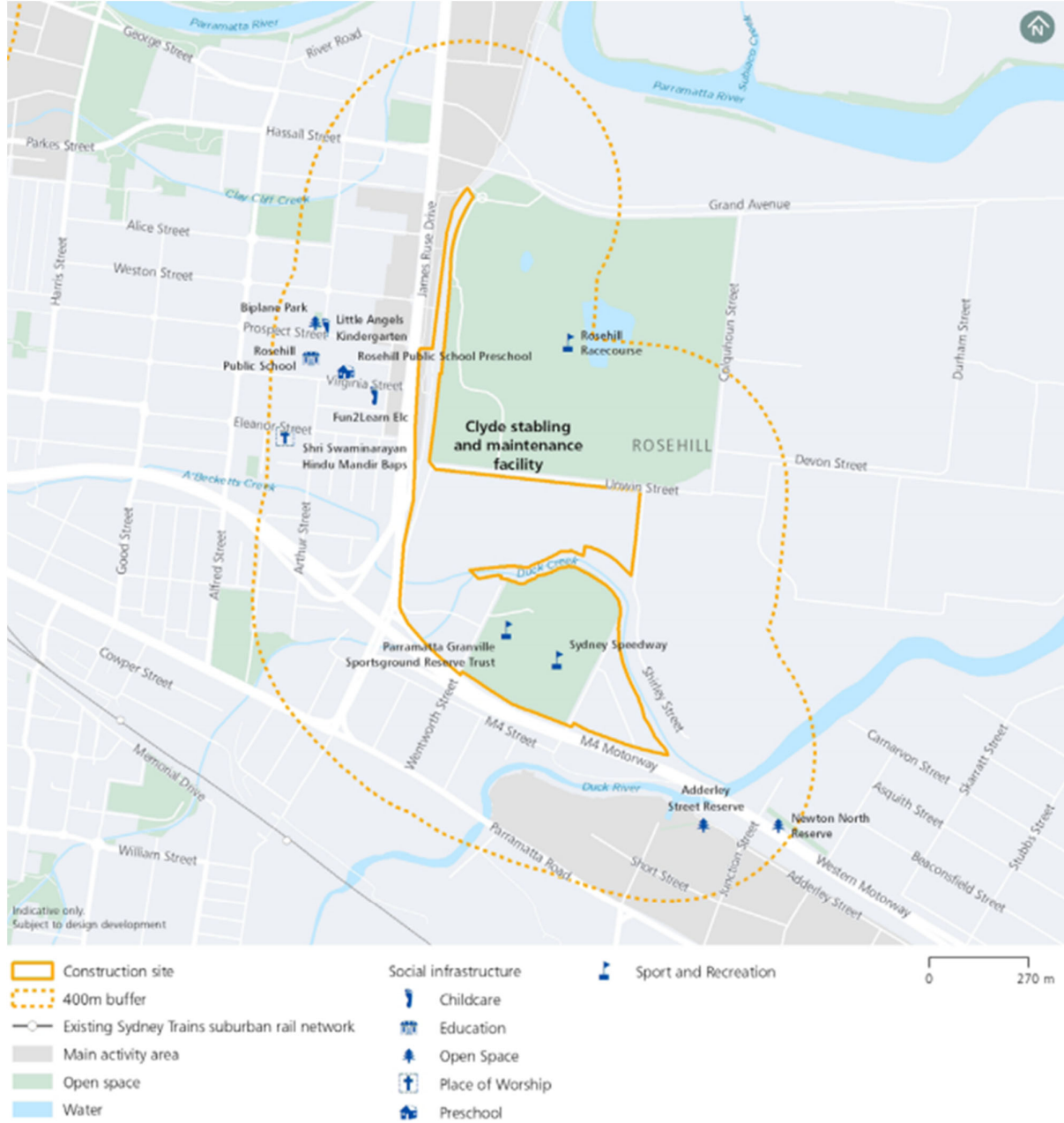

**Figure 15: Social infrastructure (Chapter 17 EIS)**

## 8 FLEET MANAGEMENT

Heavy vehicles are required to access the project work sites, which are located on the local road network within the Clyde industrial area. This section of the report provides details on the existing routes identified in the EIS documents and the scope of the routes subject to the Ministerial Conditions of Approval, specifically D87 and DELTA’s proposed site management.

Trucks to be used on the project will be compliant with NSW legislation, Sydney Metro’s Principal Contractor Health and Safety Standard, relevant Australian Design Rules and vehicle standards and the Heavy Vehicle National Legislation. All heavy vehicle operations will be conducted in accordance with DELTA’s Chain of Responsibility (CoR) Management Plan.

A combination of truck types will be used during the site operations. These trucks may be truck and dog, semi-trailers, bin trucks, 12.5m SU truck, 10 wheeler bin truck, 5t tippers and low loaders.

All trucks will enter and exit the demolition sites in a forward direction, where reasonable and feasible. Where there is a requirement to undertake reversing movements on the public road system, traffic control will be implemented.

Construction site traffic will be managed to minimise movements during peak periods, where reasonable and practicable. This will be achieved by staggered start times for trucks and daily booking of trucks ensuring that only the truck numbers required for the loading tasks for that day are ordered. Given that the trucks will be loaded sequentially this provides for a staggered release of trucks onto the road network during the AM peak. The PM peak is also reduced as typically disposal sites are closed from 5PM meaning that if the disposal site is an hour away, the latest a truck can leave site is 4PM reducing our impact on the road network.

DELTA will provide sufficient onsite parking for heavy vehicles associated with the works. This will ensure that vehicles are not idling or queuing on state and regional roads. Given the amount of space available on the demolition sites, there is no requirement for any further marshalling facilities.

### 8.1 EIS Haulage routes

The EIS nominated Wentworth Street (between Parramatta Road and the M4 overpass) and Parramatta Road/ Great Western Highway as the haulage routes into the site, as shown on Figure 16.

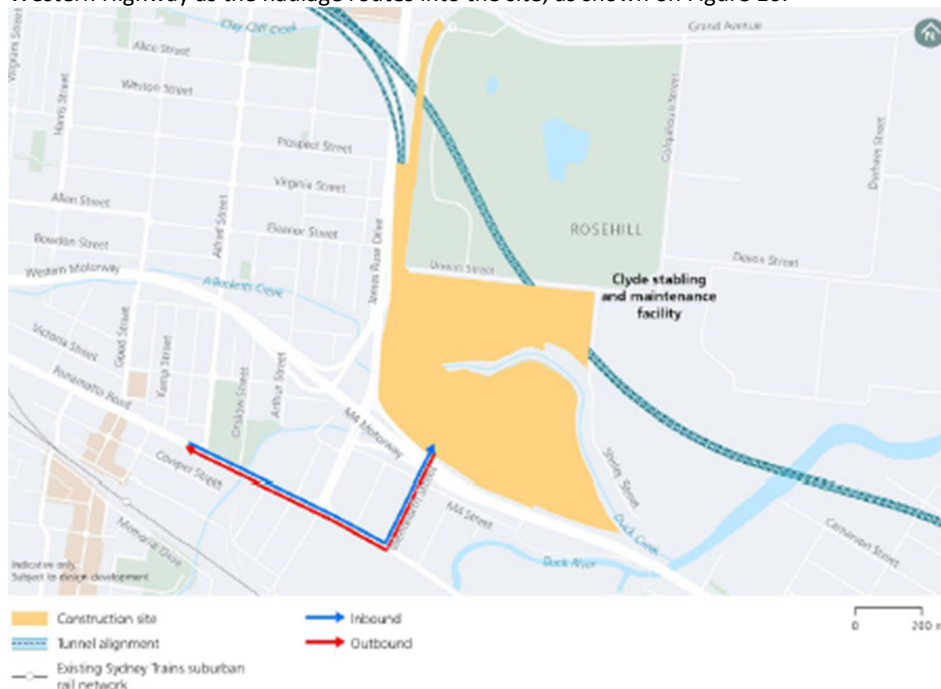

**Figure 16: EIS nominated haulage routes**

## 8.2 Proposed heavy vehicle routes and management

The local roads within the Clyde industrial area not included within the EIS and required to access/ egress the various sites, are as noted in Table 5 and shown on Figure 17, including the location of the swept paths undertaken. Heavy vehicle movements will be restricted to these routes to minimise the impact on the local road network to the north of the site and avoid the routes being used by Parramatta Light Rail and other development works in the Clyde area. The swept path analysis is provided in Appendix B with written advice from an appropriately qualified professional provided in Appendix C.

**Table 5: Roads not included in the EIS**

Road	Road classification	Between		Two way traffic flow	Parking	Speed limit
Wentworth Street	Local	M4 Motorway overpass	Duck Creek	Yes	Yes	50km/hr
Kay Street	Local	Wentworth Street	Unwin Street	Yes	Yes	50km/hr
Unwin Street	Local	Kay Street	Shirley Street	Yes	Yes	50km/hr
Shirley Street	Local	Unwin Street	Duck Creek	Yes	Yes	50km/hr

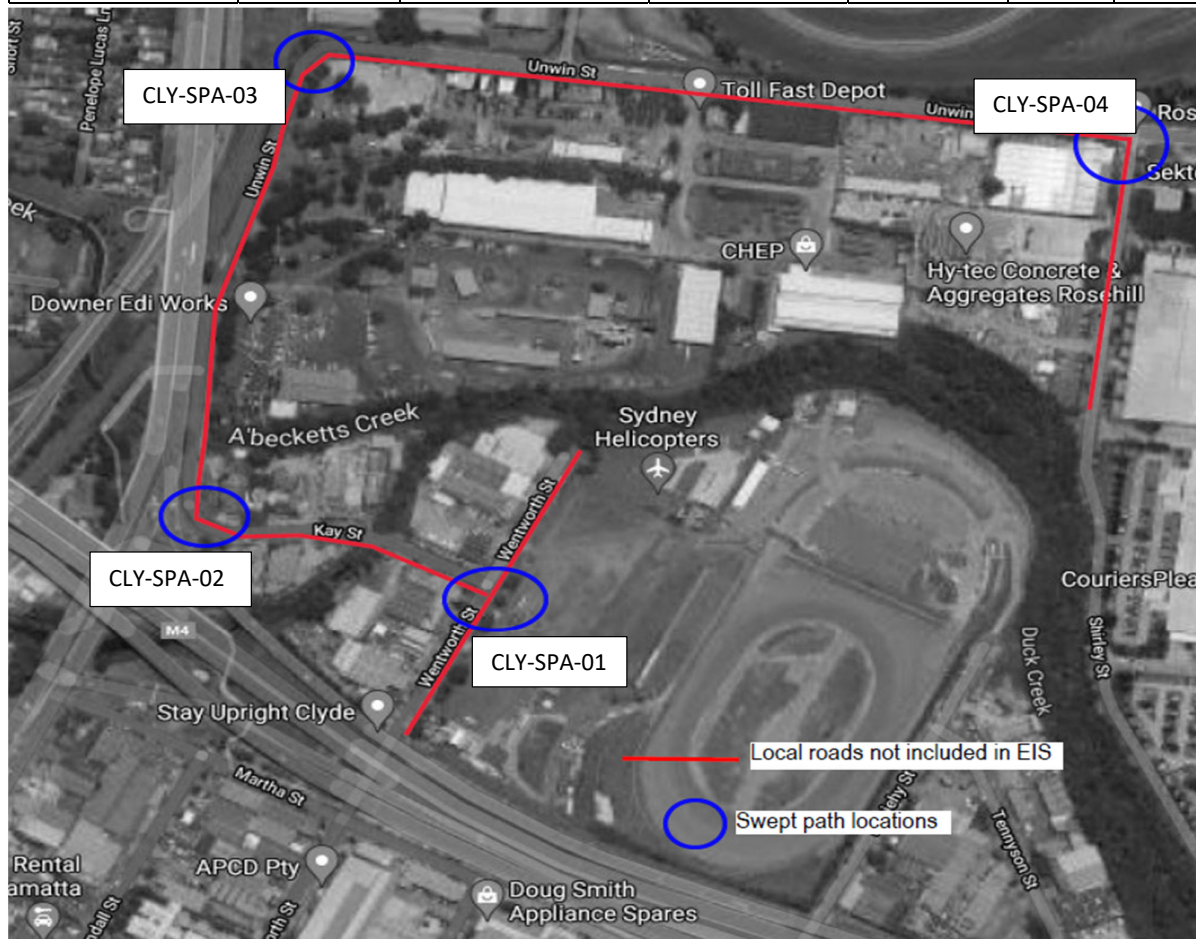

**Figure 17: Proposed routes and swept path locations**

### 8.2.1 Site management

Information on the approved routes and locations for all construction vehicles shall be provided through onsite toolbox talks, pre-start meetings and project inductions prior to commencing works on the project.

All work vehicles shall enter and exit the sites in a forward direction, where feasible and reasonable. Where this is not possible, appropriate traffic control will be in place.

We will minimise our impacts on active transport users by only using existing driveways previously in use. No further driveways are required. The swept paths included in Appendix B show no encroachment onto existing footpaths or shared paths.

It is noted that no footpaths currently exist along most of Unwin Street and that the only known cycle route crosses Wentworth Street, as noted in section 6.1 of this report.



To ensure that heavy vehicle drivers are aware of the shared path, signs will be provided upstream and downstream of Martha Street. The signs to be installed are shared path warning signs, as shown on Figure 18.



**Figure 18: Shared path warning sign**

Further signs are also proposed on Martha Street, either side of Wentworth Street to highlight the truck movements, as noted on Figure 19.

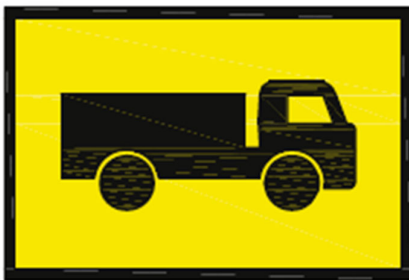

T2-25

**Figure 19: Truck warning signs**

The indicative location of the signs is shown on Figure 20



Figure 20: Indicative location of signs

An indicative site layout is provided in Figure 21.

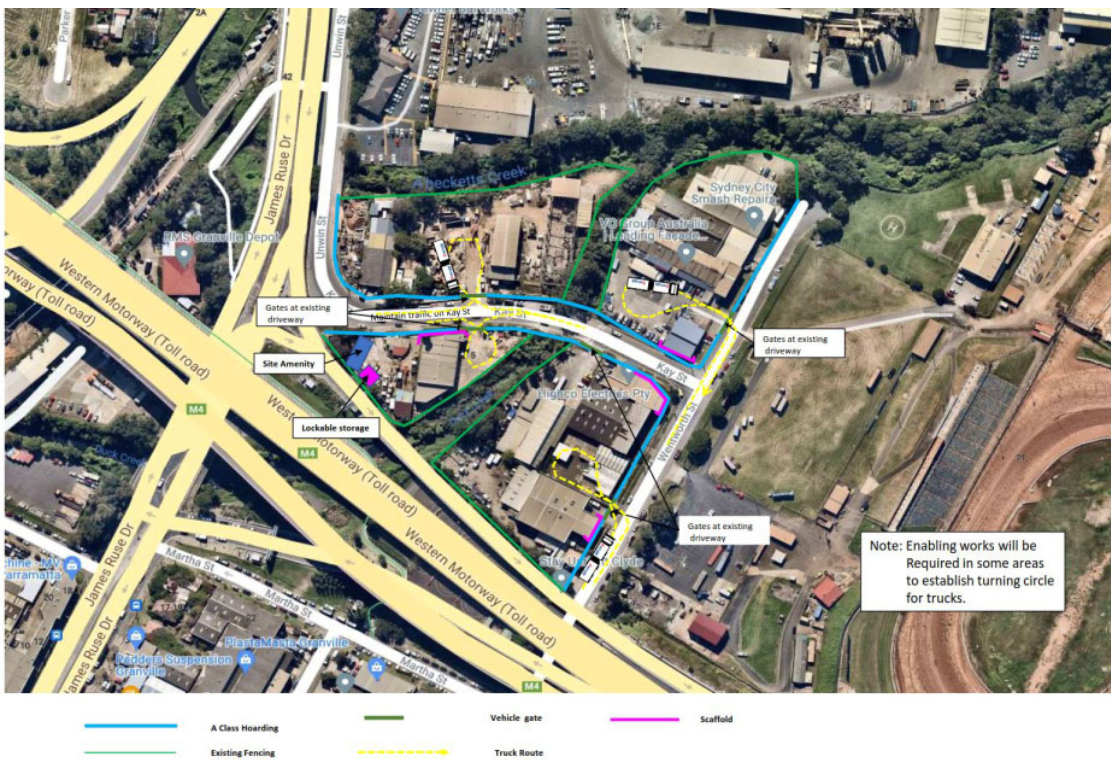

**Figure 21: Indicative site layout**

**8.2.2 Road dilapidation report**

Prior to the use of local roads by heavy vehicles associated with the works, a road dilapidation survey will be undertaken and provided to Sydney Metro and City of Parramatta Council at least one month prior to the local road use. The road dilapidation surveys were completed week commencing 20<sup>th</sup> September 2021. A copy of the transmittal to City of Parramatta Council is included in Appendix D.

**8.3 Cumulative impacts**

No cumulative impacts have been identified. Regular contact will be maintained throughout the life of the project. This will be done through attendance at the fortnightly Traffic Control Group (TCG) and monthly Traffic and Transport Liaison Group. It is noted that Parramatta Light Rail have their construction sites off Grand Avenue, to the north of Rosehill Racecourse.

**8.3.1 Traffic Control Group (TCG)**

A Traffic Control Group (TCG) has been established by Sydney Metro, meeting fortnightly. The TCG is a technical forum to discuss the proposed traffic management measures to be used during the various stages of the Project including identification of any potential impacts on the road and transport network and mitigation measures proposed, any feedback received on the traffic documentation and updates on the program of works for the various project.

**8.3.2 Traffic and Transport Liaison Group (TTLG)**

The TTLG meets monthly, and its members comprise traffic and transport stakeholders including Emergency Services.



## 9 SAFETY

DELTA is committed to safety for all aspects of the project with road safety being paramount to the success of the project. To demonstrate this commitment the requirements listed in Table 6 will be implemented. Further details on how these specific safety mitigation measures will be implemented is provided in DELTA's Chain of Responsibility Management Plan.

TfNSW have implemented a Truck Aware campaign targeting heavy vehicle drivers and other road users to promote road safety awareness, refer to [Truck Aware](#).

**Table 6: Heavy vehicle requirements**

Requirement(s)	Purpose	Managed by
Ensure all heavy vehicles are registered and comply with the Australian Design Rules and Vehicle Standards	Ensure compliance with legislative requirements	Checking prior to attendance at site and through subcontractor engagement
Blind spot elimination or minimise front, side and rear blind spots including: <ul style="list-style-type: none"> <li>Class V and Class VI mirrors as per ADR 14/02 where blind spots cannot be permanently eliminated</li> <li>The prohibition of accessories that restrict the forward field of vehicles, including opaque or chrome bug deflectors</li> </ul>	Ensure compliance with SWTC and increase visibility of active transport users	Checking prior to attendance at site and through subcontractor engagement
Side-underrun protection fitted to both sides of the vehicle: <ul style="list-style-type: none"> <li>Between the front and rear axle of all rigid (SU) trucks and</li> <li>Between the front axle/ landing legs and rear axle of trailers forming part of a combination</li> </ul>	Improved protection for active transport users	Checking prior to attendance at site and through subcontractor engagement
Signage placed on heavy vehicles including: <ul style="list-style-type: none"> <li>Rear warning signs alerting other road users to the dangers of overtaking and</li> <li>Front nearside signs warning pedestrians about walking close to the front of a moving or stationary Heavy Vehicle</li> </ul>	Increasing road safety awareness for all users	Checking prior to attendance at site and through subcontractor engagement
Full body line and contour conspicuity markings and reflective markings fitted to the drawbar of all trailers	Increasing visibility of heavy vehicles	Checking prior to attendance at site and through subcontractor engagement
Heavy Vehicle drivers to complete the Sydney Metro Safe Heavy Vehicle Driver Introduction Program or equivalent	Training and induction to address safety of pedestrians and bike riders at the crossing of Wentworth St for shared path along Martha Street	Training and Induction process
All Heavy Vehicles used for spoil haulage must be clearly marked on the sides and rear with the project name and application number to enable immediate identification by a person viewing the Heavy Vehicle standing 20m away	Compliance with MCoA	Checking prior to attendance at site and through subcontractor engagement

## 10 CONSULTATION AND COMMUNICATION

### 10.1 Stakeholders consulted

Table 7 lists the consultation undertaken in the development of this Heavy Vehicle Local Road report. Appendix A contains comments from the various stakeholders and DELTA's responses. All consultation will be undertaken in accordance with:

- Sydney Metro's Overarching Community Communications Strategy
- Small Business Owners Engagement Plan
- Contractor specific community communication strategy

Consultation with appropriate stakeholders would continue as and when required should heavy vehicle route requirements need to be changed in the future.

**Table 7: Stakeholders consulted**

Stakeholder	Date	Consultation	Main contact people
Traffic Control Group	19 August 2021	Presentation	Sydney Metro, CJP, Council, Other Parramatta Contractors
Sydney Metro including Road Safety, Operations, Customer and Place Making	25 August 2021	Submission of report	████████████████████
TfNSW Customer Journey Planning	25 August 2021	Submission of report	██████████
TfNSW Planning and Program	25 August 2021	Submission of report	████████████████
City of Parramatta Council	25 August 2021	Submission of report	Council
Sydney Metro including Road Safety, Operations, Customer and Place Making	17 <sup>th</sup> September 2021	Resubmission of report	████████████████████
TfNSW Customer Journey Planning	17 <sup>th</sup> September 2021	Resubmission of report	██████████
TfNSW Planning and Program	17 <sup>th</sup> September 2021	Resubmission of report	████████████████
City of Parramatta Council	17 <sup>th</sup> September 2021	Resubmission of report	Council
Sydney Metro including Road Safety, Operations, Customer and Place Making	1 <sup>st</sup> October 2021	Resubmission of report	████████████████████
TfNSW Customer Journey Planning	1 <sup>st</sup> October 2021	Resubmission of report	██████████
TfNSW Planning and Program	1 <sup>st</sup> October 2021	Resubmission of report	████████████████
City of Parramatta Council	1 <sup>st</sup> October 2021	Resubmission of report	Council
Sydney Metro including Road Safety, Operations,	12 <sup>th</sup> October 2021	Resubmission of report	████████████████████

Stakeholder	Date	Consultation	Main contact people
Customer and Place Making			
TfNSW Customer Journey Planning	12 <sup>th</sup> October 2021	Resubmission of report	██████████
TfNSW Planning and Program	12 <sup>th</sup> October 2021	Resubmission of report	██████████
City of Parramatta Council	12 <sup>th</sup> October 2021	Resubmission of report	Council

### 10.2 Induction

All personnel, including subcontractors, are required to attend a compulsory site induction before commencing any works on site. Similarly, visitors will be required to undertake a Visitor’s induction. The heavy vehicle routes as detailed within this report and included in the CTMP, will be included as part of the mandatory induction. A record of all inductions will be maintained.

### 10.3 Toolbox talks

Toolbox talks will be conducted weekly as a minimum and will be used to present the status of safety and environmental performance including the compliance with this report and the approved CTMP for the site.

## APPENDICES

### A. Received comments



<b>Project</b>	CSSI 10038 – Sydney Metro West
<b>Document</b>	Clyde HVLR
<b>Date received from Sydney Metro</b>	18 September 2021
<b>Date comments sent to Sydney Metro</b>	30 September 2021

Com ment No.	CoA	Requirement	Document reference	DPIE comment	Project team response	Amend ment made Y/N?	Page/section	DPIE Comment	Final Status
1	D86	Local roads proposed to be used by Heavy Vehicles to directly access construction sites that are not identified in the documents listed in Condition A1 of this schedule must be approved by the Planning Secretary and be included in the CTMPs.		Table 5 of the HVLR contains a list of roads to be used that are not identified in the EIS. Figure 17 displays these roads and swept path locations.  <b>CLOSED</b>	Noted	N	NA		
2	D87	All requests to the Planning Secretary for approval to use local roads under <b>Condition D86</b> above must include the following:							
3	D87(a)	A swept path analysis		Appendix B of the HVLR contains the results of the swept path analyses. Swept path analyses are included for; the Wentworth Street and Kay Street intersection, Kay Street, Unwin Street and the Shirley Street and Unwin Street intersection.  <b>CLOSED</b>	Noted	N	NA		
4	D87(b)	Demonstration that the use of local roads by Heavy Vehicles for the CSSI will not compromise the safety of pedestrians and cyclists of the safety of two way traffic flow on two way roadways		Section 8.2.1 of the HVLR contains commitments to safety and minimisation of impact for active transport users. This section also contains safety signs (shared path warnings) that will be installed upstream and downstream of Martha Street. Table 5 of the HVLR states that two way traffic flow will be maintained on Wentworth Street, Kay Street, Unwin Street and Shirley Street.  <b>CLOSED</b>	Noted	N	NA		
5	D87(c)	Details as to the date of completion of the road dilapidation surveys for the subject local roads and							
6	D87(d)	Measures that will be implemented to avoid where practicable the use of local roads past schools, aged care facilities childcare facilities during their peak operation times		It is noted that no schools, aged care or child care facilities are within the vicinity of the nominated routes.  <b>CLOSED</b>	Noted	N	NA		
7	D87(e)	Written advice from an appropriately qualified professional on the suitability of the proposed Heavy Vehicle route which takes into consideration items (a) to (d)		Appendix C contains written advice from an appropriately qualified professional. The advice concludes that the proposed use of local roads is expected to have limited to no adverse impact on pedestrians or sensitive receivers.  <b>CLOSED</b>	Noted	N	NA		
8	D88	Before any local road is used by a Heavy Vehicle for the purposes of construction of Stage 1 of the CSSI, a Road Dilapidation Report must be prepared for the road. A copy of the Road Dilapidation Report must be provided to the Relevant Road Authority(s) within three (3) weeks of completion of the survey and at no later than one (1) month before the road being used by Heavy Vehicles associated with the construction of Stage 1 of the CSSI		Section 8.2.2 of the HVLR states "The road dilapidation surveys will be completed by 20th September 2021 and the reports provided to Council that week."  <b>DPIE comment 5.1: Please provide evidence that the dilapidation reports have been provided to council</b>	Transmittal included as Appendix D		Appendix D		
<b>Revised Environmental Mitigation Measures</b>									
9	TT6	All trucks would enter and exit construction sites in a forward direction, where feasible and reasonable		Section 8 of the HVLR contains commitments to having all trucks enter construction sites in the forward direction where feasible and reasonable.	Noted	N	NA		

Com ment No.	CoA	Requirement	Document reference	DPIE comment	Project team response	Amend ment made Y/N?	Page/section	DPIE Comment	Final Status
				<b>CLOSED</b>					
10	TT7	Construction site traffic would be managed to minimise movements during peak periods		Section 8 of the HVLR commits to managing construction traffic to minimise movements during peak periods by staggering times and using a booking system.  <b>CLOSED</b>	Noted	N	NA		
11	TT8	Construction site traffic immediately around construction sites would be managed to minimise vehicle movements through school zones during pick up and drop off times		It is noted that there are no school zones in the vicinity of the construction area.  <b>CLOSED</b>	Noted	N	NA		
12	TT24	Coordination and consultation with the following stakeholders would occur, where required, to manage the interface of projects under construction at the same time: <ul style="list-style-type: none"> <li>• Transport for NSW including Transport Coordination</li> <li>• Department of Planning, Industry and Environment</li> <li>• Sydney Trains</li> <li>• NSW Trains</li> <li>• Sydney Buses</li> <li>• Sydney Water</li> <li>• Port Authority of NSW</li> <li>• Sydney Motorways Corporation</li> <li>• Emergency service providers</li> <li>• Utility providers</li> </ul> Construction contractors Coordination and consultation with these stakeholders would include: <ul style="list-style-type: none"> <li>• Provision of regular updates to the detailed construction program, construction sites and haul routes</li> <li>• Identification of key potential conflict pints with other construction projects</li> <li>• Developing mitigation strategies in order to manage conflicts. Depending on the nature of the conflict this could involve: <ul style="list-style-type: none"> <li>○ Adjustments to the Sydney Metro construction program work activities or haul routes or adjustments to the program activities or haul routes of other construction projects</li> <li>○ Coordination of traffic management arrangements between projects</li> </ul> </li> </ul>		Table 10 in Section 9 of the HVLR contains a list of the consultation undertaken during the preparation of the plan. Appendix A contains a list of received comments.  <b>CLOSED</b>	Noted	N	NA		
<b>General Comments</b>									
13				Appendix A of the HVLR contains the consultation feedback comments. It is unclear in the table which comments remain outstanding and which comments have been fully closed out. Please amend the plan to clearly show that all comments have been addressed, or reasons why they have not been addressed.	All comments are now closed	Y	Appendix A		

DOCUMENT NO.	TITLE	VER	STATUS	NO.	DATE	COMPANY	RAISED BY	REVIEW DOC. NO.*	DOCUMENT REF*	DEED REF*	COMMENTS / RESPONSE	COMMENT CATEGORY*	CLOSED OUT
SMWSDDS-DLT-CLJ-TF-PLN-000031	Heavy Vehicle Local Roads Report (Clyde)	03.01	RVW	24	8/09/2021	PAR	[REDACTED]	SMWSDDS-DLT-CLJ-TF-PLN-000031	Section 8 Safety, Table 6: Heavy vehicle requirements	n/a	For row with "Heavy Vehicle drivers to complete to (sic) the Sydney Metro Safe Heavy Vehicle Drive Introduction Program or equivalent" add to this induction, to address safety of pedestrians and bike riders, the crossing of Wentworth St for shared path along Martha St	Observation	Y
							[REDACTED]	SMWSDDS-DLT-CLJ-TF-PLN-000031	Section 8 Safety, Table 6: Heavy vehicle requirements	n/a		Observation	Y
				24.01	20/09/2021	DLT	[REDACTED]	SMWSDDS-DLT-CLJ-TF-PLN-000031	Section 8 Safety, Table 6: Heavy vehicle requirements	n/a	Document amended	Observation	Y
							[REDACTED]	SMWSDDS-DLT-CLJ-TF-PLN-000031	Section 8 Safety, Table 6: Heavy vehicle requirements	n/a		Observation	Y
				25	8/09/2021	PAR	[REDACTED]	SMWSDDS-DLT-CLJ-TF-PLN-000031	Appendix B, Dwg No CLY-SPA-02	n/a	19.5m semi trailer swept path seems to be omitted from the Kay St SW corner swept path analysis	Observation	Y
							[REDACTED]	SMWSDDS-DLT-CLJ-TF-PLN-000031	Appendix B, Dwg No CLY-SPA-02	n/a		Observation	Y
				25.01	20/09/2021	DLT	[REDACTED]	SMWSDDS-DLT-CLJ-TF-PLN-000031	Appendix B, Dwg No CLY-SPA-02	n/a	Noted included now	Observation	Y
							[REDACTED]	SMWSDDS-DLT-CLJ-TF-PLN-000031	Appendix B, Dwg No CLY-SPA-02	n/a		Observation	Y
				26	8/09/2021	PAR	[REDACTED]	SMWSDDS-DLT-CLJ-TF-PLN-000031	Appendix B, Dwg No CLY-SPA-04	n/a	19.5m semi trailer swept path seems to be omitted for the Unwin St and Shirley St intersection swept path analysis	Observation	Y
							[REDACTED]	SMWSDDS-DLT-CLJ-TF-PLN-000031	Appendix B, Dwg No CLY-SPA-04	n/a		Observation	Y
				26.01	20/09/2021	DLT	[REDACTED]	SMWSDDS-DLT-CLJ-TF-PLN-000031	Appendix B, Dwg No CLY-SPA-04	n/a	The semi trailer swept path is now included and shown that this movement is not possible without civil works.	Observation	Y
							[REDACTED]	SMWSDDS-DLT-CLJ-TF-PLN-000031	Appendix B, Dwg No CLY-SPA-04	n/a		Observation	Y
				27	8/09/2021	PAR	[REDACTED]	SMWSDDS-DLT-CLJ-TF-PLN-000031	-	n/a	It has been proposed that the applicant will provide a dilapidation report for affected roads. Once the project is completed, they will either rectify any damage or pay for its repair. This is fine, however, there is no information on the regime of regular road inspections and who will be doing maintenance during the project.	Observation	Y
							[REDACTED]	SMWSDDS-DLT-CLJ-TF-PLN-000031	-	n/a		Observation	Y
				27.01	20/09/2021	DLT	[REDACTED]	SMWSDDS-DLT-CLJ-TF-PLN-000031	-	n/a	There is no requirement to undertake maintenance.	Observation	Y
							[REDACTED]	SMWSDDS-DLT-CLJ-TF-PLN-000031	-	n/a		Observation	Y
				27.01.01	11/10/2021	PAR	[REDACTED]				Please retain this comment to transfer to the next contract (as suggested by Varun Kulkarni by telephone). Council is concerned that a mechanism is put in place to protect Council's investment in roads over successive stages of construction.	Observation	Y
							[REDACTED]					Observation	Y
				28	8/09/2021	PAR	[REDACTED]	SMWSDDS-DLT-CLJ-TF-PLN-000031	-	n/a	There is no information on any compensation to Council for long term damage to road pavements such as an increase in pavement wear as result of increased number of heavy vehicles on roads. During another project that affected some roads in Epping (Sydney Metro North project), CoP received compensation for increased number of buses on our roads during the closure of railway line. The compensation was calculated in accordance with TfNSW publication: Roads and Maritime Services Report, Analysis of Marginal Cost of Road Wear - Based on pavement life cycle costing', 21st April 2011. Could the same methodology be used in this case?	Observation	Y
							[REDACTED]	SMWSDDS-DLT-CLJ-TF-PLN-000031	-	n/a		Observation	Y
				28.01	20/09/2021	DLT	[REDACTED]	SMWSDDS-DLT-CLJ-TF-PLN-000031	-	n/a	Road dilapidation surveys are to be undertaken prior to the commencement of works and post completion. Any impacts to Councils roads will be the subject of discussions post the completion of the road dilapidation report	Observation	Y
							[REDACTED]	SMWSDDS-DLT-CLJ-TF-PLN-000031	-	n/a		Observation	Y

DOCUMENT NO.	TITLE	VER	STATUS	NO.	DATE	COMPANY	RAISED BY	REVIEW DOC. NO.*	DOCUMENT REF*	DEED REF*	COMMENTS / RESPONSE	COMMENT CATEGORY*	CLOSED OUT
				28.01.01	11/10/2021	PAR	[REDACTED]				Please retain this comment to transfer to the next contract (as suggested by Varun Kulkarni by telephone). Council is concerned that a mechanism is put in place to protect Council's investment in roads over successive stages of construction.	Observation	Y
							[REDACTED]					Observation	Y
				29	8/09/2021	PAR	[REDACTED]	SMWSDDS-DLT-CLJ-TF-PLN-000031		n/a	The applicant provided map showing that the affected roads are part of PBS network. This map must be read in conjunction with map of restricted structures. There are two bridges at Unwin Street and Kay Street for which Council does not have information on the load bearing capacity. It would be wise to conduct structural assessment of these bridges before PBS vehicles are allowed to travel over them.	Observation	Y
							[REDACTED]	SMWSDDS-DLT-CLJ-TF-PLN-000031		n/a		Observation	Y
				29.01	20/09/2021	DLT	[REDACTED]	SMWSDDS-DLT-CLJ-TF-PLN-000031		n/a	Noted PBS vehicles will not be used at this site	Observation	Y
							[REDACTED]	SMWSDDS-DLT-CLJ-TF-PLN-000031		n/a		Observation	Y
				30	8/09/2021	PAR	[REDACTED]	SMWSDDS-DLT-CLJ-TF-PLN-000031		n/a	Due to installation of underground utility services, some of our road sections (pavements or footpath areas) might be affected. There needs to be an agreement on road restoration in accordance with Council's procedures.	Observation	Y
							[REDACTED]	SMWSDDS-DLT-CLJ-TF-PLN-000031		n/a		Observation	Y
				30.01	20/09/2021	DLT	[REDACTED]	SMWSDDS-DLT-CLJ-TF-PLN-000031		n/a	Noted	Observation	Y
							[REDACTED]	SMWSDDS-DLT-CLJ-TF-PLN-000031		n/a		Observation	Y
				32	21/09/2021	SMD	[REDACTED]	SMWSDDS-DLT-CLJ-TF-PLN-000031 Rev : 01	Figure 4	NA	Would be more appropriate to use the traffic data provided in the EIS1 Traffic & Transport Technical Paper, which is 2019 data.	Observation	N
							[REDACTED]	SMWSDDS-DLT-CLJ-TF-PLN-000031 Rev : 01	Figure 4	NA	This data is included within the revised document	Observation	N
				32.01	6/10/2021	SMD	[REDACTED]	SMWSDDS-DLT-CLJ-TF-PLN-000031 Rev : 03	Figure 4 & 5	NA	Both the figures provide traffic volumes prior to TfNSW occupation of the site. The change in traffic volumes would be the result of other changes within the Clyde/Camellia industrial area or seasonal variations.	Observation	N
							[REDACTED]	SMWSDDS-DLT-CLJ-TF-PLN-000031 Rev : 03	Figure 4 & 5	NA	Noted	Observation	N
				32.01.01	11/10/2021	SMD	[REDACTED]				Page 13 - suggest delete paragraph 'A review of traffic studies undertaken .....refer to Figure 4' and delete Figure 4 table 'Table 2.1...' including 2 following dot points. Page 14 - suggest replacing opening sentence to 'Figure 5 provides peak period traffic volumes on Wentworth Street.'	Observation	N
							[REDACTED]				Document amended	Observation	N
				41	1/10/2021	SMD	[REDACTED]	SMWSDDS-DLT-CLJ-TF-PLN-000031	Whole document - DPIE comments	na	Comments from DPIE provided in the attached to be addressed.	Actual Non-Compliance	N
							[REDACTED]	SMWSDDS-DLT-CLJ-TF-PLN-000031	Whole document - DPIE comments	na	Comments addressed	Actual Non-Compliance	N
				41.01	6/10/2021	DLT	[REDACTED]				Comments all addressed in Appendix	Actual Non-Compliance	N
							[REDACTED]				Comments addressed	Actual Non-Compliance	N
				42	7/10/2021	SMD	[REDACTED]				No Comments		N
							[REDACTED]				NA		N
				43	11/10/2021	PAR	[REDACTED]	SMWSDDS-DLT-CLJ-TF-PLN-000031	Page 48 of 53, CLY-SPA-04-ST	N/A	Swept path of 19.5m SEMI from Shirley St left into Unwin St mounts the SW kerb substantially. Request if damaged by SMW demolition / construction SEMI's, that Sydney Metro repair the damaged kerb	Minor Non-Compliance	N
							[REDACTED]	SMWSDDS-DLT-CLJ-TF-PLN-000031	Page 48 of 53, CLY-SPA-04-ST	N/A	Semi trailers are not proposed to access Shirley Street from Unwin Street. This access will be limited to 19m truck and dogs or smaller vehicles	Minor Non-Compliance	N

## B.Swept path analysis

Drawing	Location	Suitability	Truck type
CLY-SPA-01-ST	Wentworth Street at Kay Street	Swept path is suitable	Semi-trailer
CLY-SPA-01-TD	Wentworth Street at Kay Street	Swept path is suitable	Truck and dog combination
CLY-SPA-02-ST	Kay Street at Unwin Street	Swept path is suitable	Semi-trailer
CLY-SPA-02-TD	Kay Street at Unwin Street	Swept path is suitable	Truck and dog combination
CLY-SPA-03-ST	Unwin Street at Unwin Street	Swept path is suitable	Semi-trailer
CLY-SPA-03-TD	Unwin Street at Unwin Street	Swept path is suitable	Truck and dog combination
CLY-SPA-04-ST	Unwin Street at Shirley Street	Swept path is <b>NOT</b> suitable	Semi-trailer
CLY-SPA-04-TD	Unwin Street at Shirley Street	Swept path is suitable	Truck and dog combination







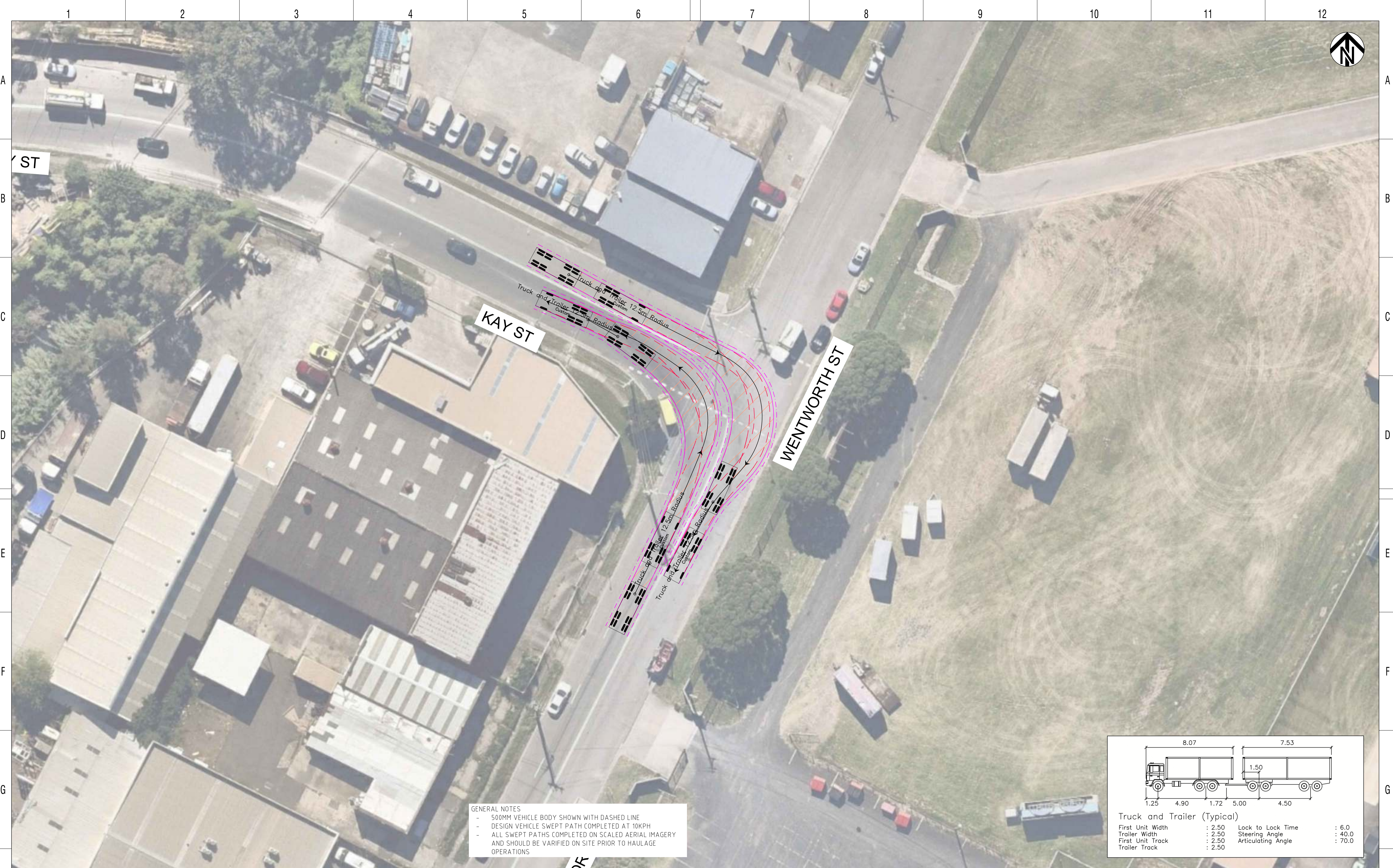

GENERAL NOTES  
 - 500MM VEHICLE BODY SHOWN WITH DASHED LINE  
 - DESIGN VEHICLE SWEEP PATH COMPLETED AT 10KPH  
 - ALL SWEEP PATHS COMPLETED ON SCALED AERIAL IMAGERY AND SHOULD BE VARIFIED ON SITE PRIOR TO HAULAGE OPERATIONS

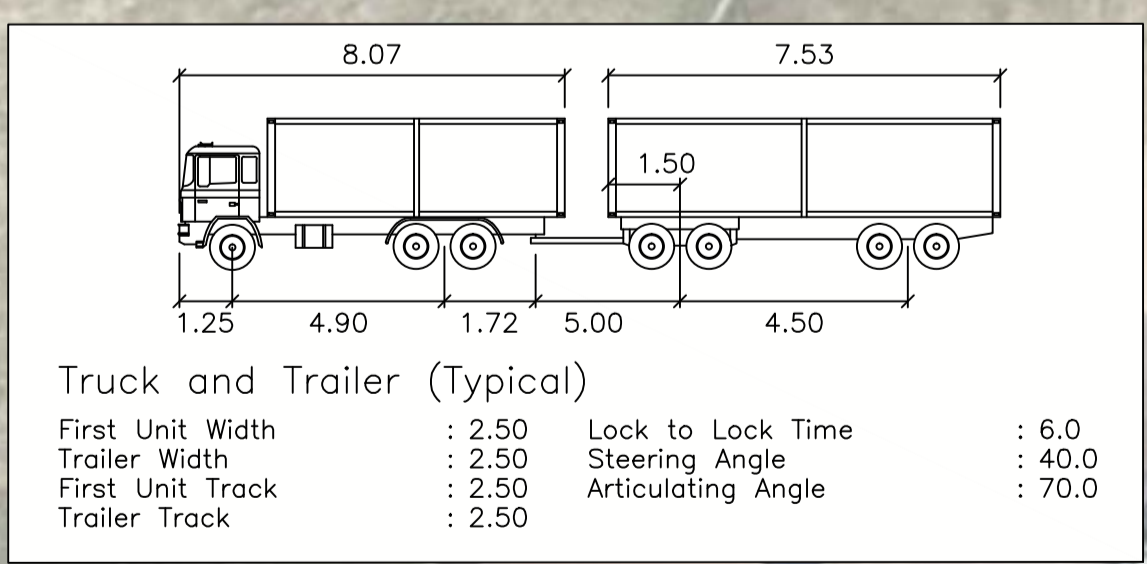

REV	BY	DATE	DESCRIPTION	APPD.
A	SS	16/08/21	INITIAL DRAFT	SL
COORDINATE SYSTEM:			HEIGHT DATUM:	SCALE:

DRAWN BY:	SS
DRW CHECK:	SL
APPROVED:	SL
IND REVIEW:	SL

PROJECT  
 CLIENT

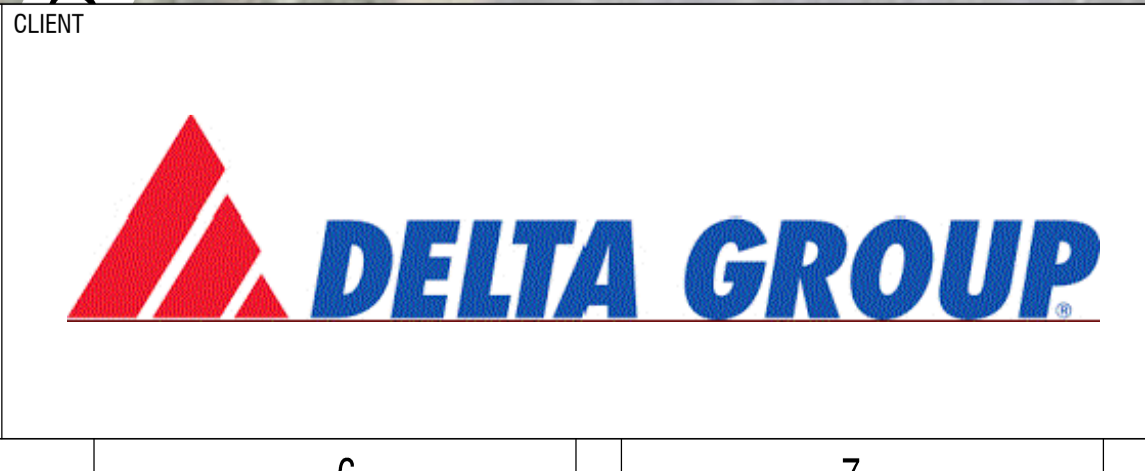

DELTA  
 CLYDE  
 SWEEP PATH ANALYSIS

DRAWING No:	CLY-SPA-01-TD		
SHEET	1	OF	1
REVISION	A		



GENERAL NOTES  
 - 500MM VEHICLE BODY SHOWN WITH DASHED LINE  
 - DESIGN VEHICLE SWEEP PATH COMPLETED AT 10KPH  
 - ALL SWEEP PATHS COMPLETED ON SCALED AERIAL IMAGERY AND SHOULD BE VERIFIED ON SITE PRIOR TO HAULAGE OPERATIONS

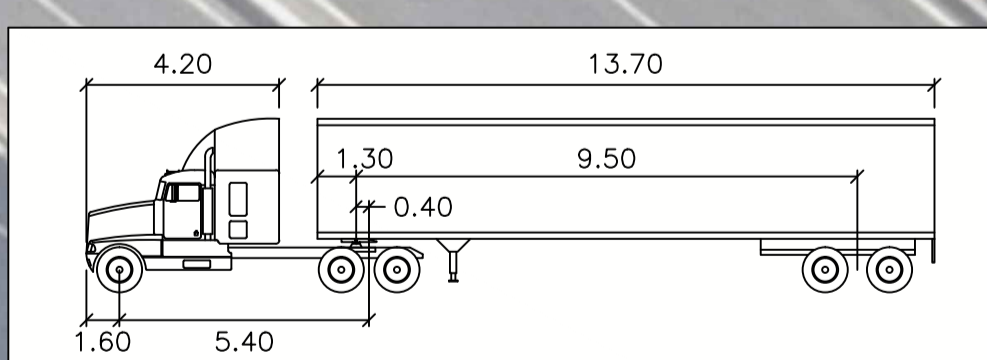

SEM1		meters	
Tractor Width	: 2.50	Lock to Lock Time	: 6.0
Trailer Width	: 2.50	Steering Angle	: 28.4
Tractor Track	: 2.50	Articulating Angle	: 70.0
Trailer Track	: 2.50		

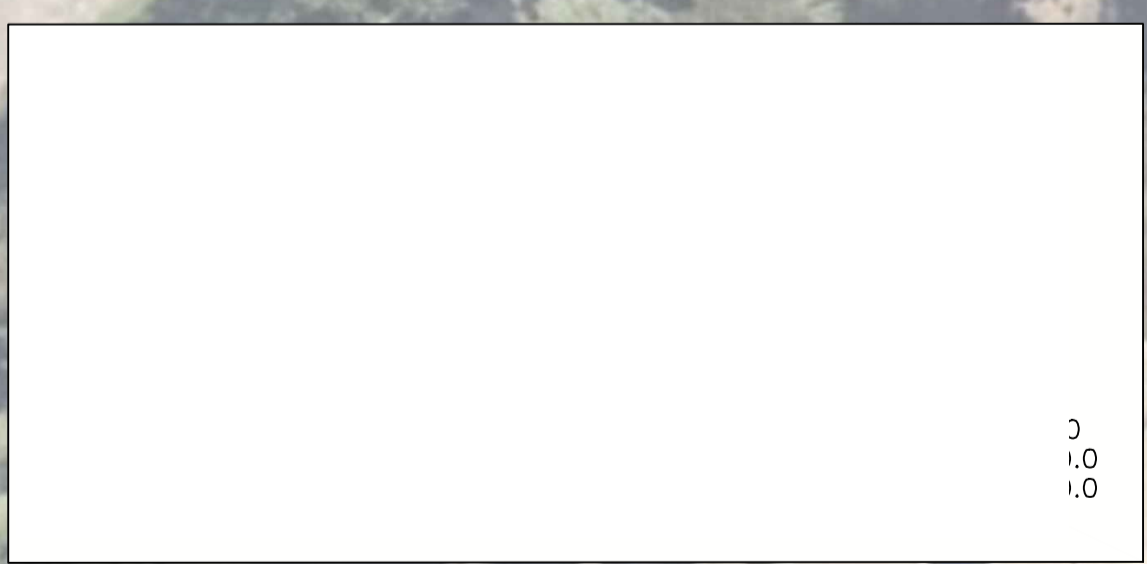

DRAWN BY:	SS
DRW CHECK:	SL
APPROVED:	SL
IND REVIEW:	SL

PROJECT

CLIENT



DELTA  
 CLYDE  
 SWEEP PATH ANALYSIS

DRAWING No: CLY-SPA-02-ST

SHEET 1 OF 1

REVISION A

REV	BY	DATE	DESCRIPTION	APPD.
A	SS	16/08/21	INITIAL DRAFT	SL

COORDINATE SYSTEM:	HEIGHT DATUM:	SCALE:
--------------------	---------------	--------



GENERAL NOTES  
 - 500MM VEHICLE BODY SHOWN WITH DASHED LINE  
 - DESIGN VEHICLE SWEEP PATH COMPLETED AT 10KPH  
 - ALL SWEEP PATHS COMPLETED ON SCALED AERIAL IMAGERY AND SHOULD BE VARIFIED ON SITE PRIOR TO HAULAGE OPERATIONS

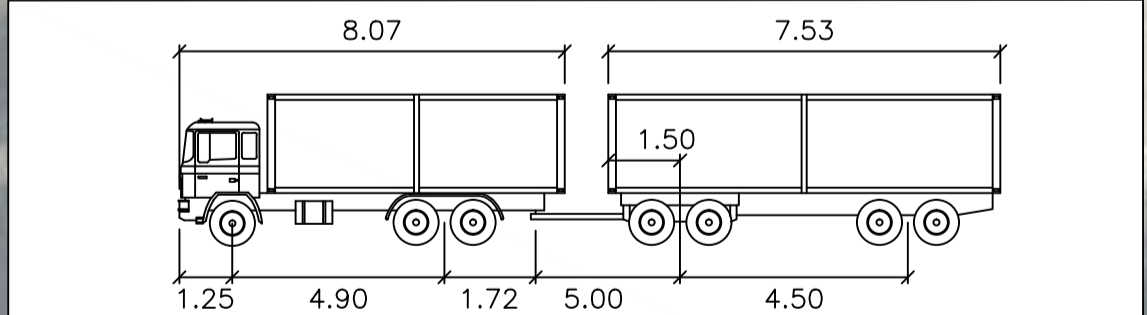

Truck and Trailer (Typical)			
First Unit Width	: 2.50	Lock to Lock Time	: 6.0
Trailer Width	: 2.50	Steering Angle	: 40.0
First Unit Track	: 2.50	Articulating Angle	: 70.0
Trailer Track	: 2.50		

DRAWN BY:	SS
DRW CHECK:	SL
APPROVED:	SL
IND REVIEW:	SL

PROJECT  
 CLIENT



DELTA  
 CLYDE  
 SWEEP PATH ANALYSIS

DRAWING No:	CLY-SPA-03-TD	
SHEET	1	OF 1
REVISION	A	

REV	BY	DATE	DESCRIPTION	APPD.
A	SS	16/08/21	INITIAL DRAFT	SL
COORDINATE SYSTEM:		HEIGHT DATUM:	SCALE:	



GENERAL NOTES  
 - 500MM VEHICLE BODY SHOWN WITH DASHED LINE  
 - DESIGN VEHICLE SWEEP PATH COMPLETED AT 10KPH  
 - ALL SWEEP PATHS COMPLETED ON SCALED AERIAL IMAGERY AND SHOULD BE VARIFIED ON SITE PRIOR TO HAULAGE OPERATIONS

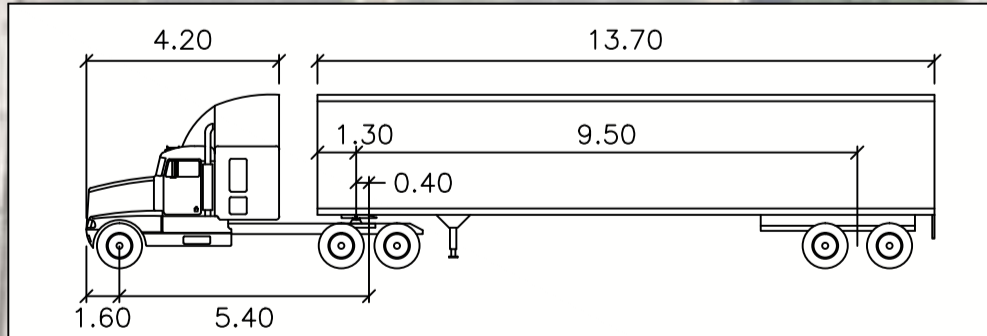

SEM1		meters	
Tractor Width	: 2.50	Lock to Lock Time	: 6.0
Trailer Width	: 2.50	Steering Angle	: 28.4
Tractor Track	: 2.50	Articulating Angle	: 70.0
Trailer Track	: 2.50		

REV	BY	DATE	DESCRIPTION	APPD.
A	SS	16/08/21	INITIAL DRAFT	SL
COORDINATE SYSTEM:			HEIGHT DATUM:	SCALE:

DRAWN BY:	SS	PROJECT
DRW CHECK:	SL	CLIENT
APPROVED:	SL	
IND REVIEW:	SL	



DELTA  
 CLYDE  
 SWEEP PATH ANALYSIS

DRAWING No:	CLY-SPA-03-ST	
SHEET	1	OF 1
REVISION	A	



GENERAL NOTES  
 - 500MM VEHICLE BODY SHOWN WITH DASHED LINE  
 - DESIGN VEHICLE SWEEP PATH COMPLETED AT 10KPH  
 - ALL SWEEP PATHS COMPLETED ON SCALED AERIAL IMAGERY AND SHOULD BE VERIFIED ON SITE PRIOR TO HAULAGE OPERATIONS

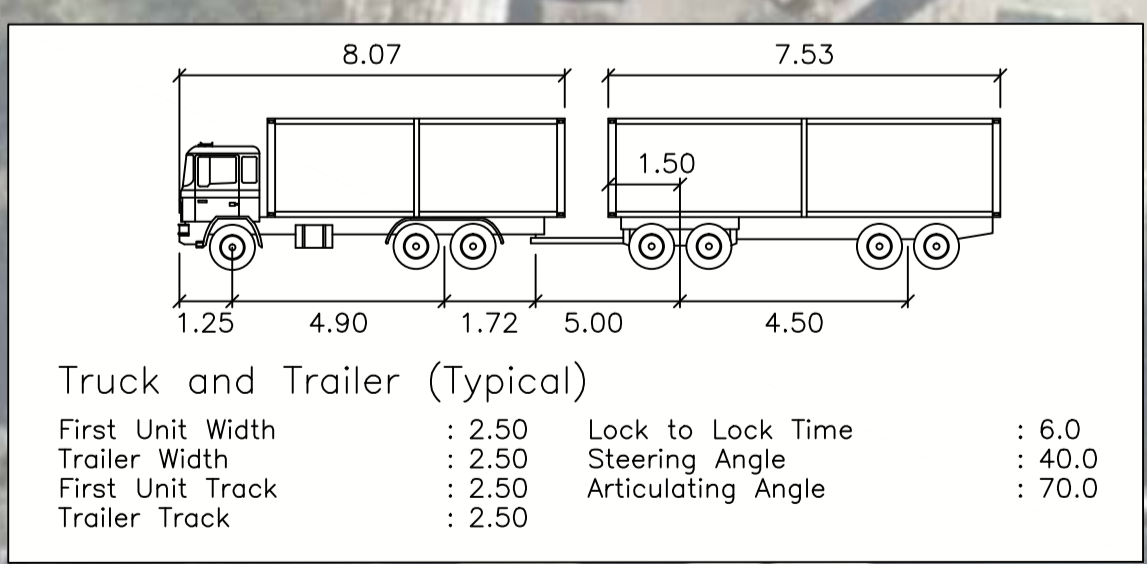

DRAWN BY: SS  
 DRW CHECK: SL  
 APPROVED: SL  
 IND REVIEW: SL

PROJECT  
 CLIENT



DELTA  
 CLYDE  
 SWEEP PATH ANALYSIS

DRAWING No: CLY-SPA-03-TD

SHEET 1 OF 1

REVISION A

REV	BY	DATE	DESCRIPTION	APPD.
A	SS	16/08/21	INITIAL DRAFT	SL

COORDINATE SYSTEM:      HEIGHT DATUM:      SCALE:





**GENERAL NOTES**  
 - 500MM VEHICLE BODY SHOWN WITH DASHED LINE  
 - DESIGN VEHICLE SWEEP PATH COMPLETED AT 10KPH  
 - ALL SWEEP PATHS COMPLETED ON SCALED AERIAL IMAGERY  
 AND SHOULD BE VERIFIED ON SITE PRIOR TO HAULAGE  
 OPERATIONS

A

A

B

B

C

C

D

D

E

E

F

F

G

G

H

H

UNWIN ST

SHIRLEY ST

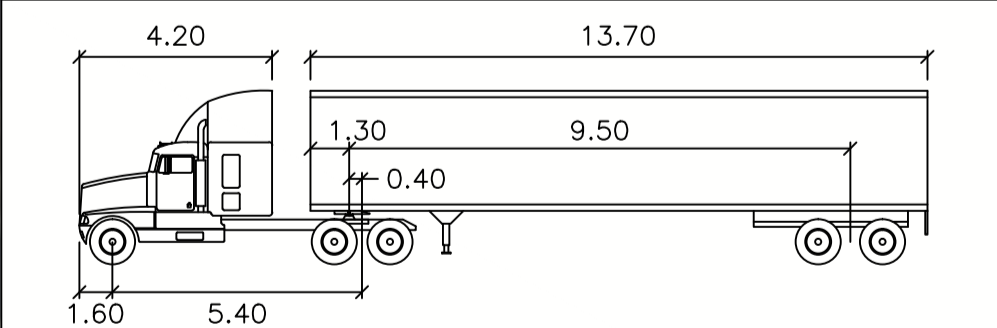

SEM1		meters	
Tractor Width	: 2.50	Lock to Lock Time	: 6.0
Tractor Track	: 2.50	Steering Angle	: 28.4
Tractor Wheelbase	: 5.40	Articulating Angle	: 70.0
Trailer Width	: 13.70		
Trailer Track	: 2.50		

DRAWN BY:	SS
DRW CHECK:	SL
APPROVED:	SL
IND REVIEW:	SL

PROJECT

CLIENT



DELTA  
 CLYDE  
 SWEEP PATH ANALYSIS

DRAWING No: **CLY-SPA-04-ST**

SHEET **1** OF **1**

REVISION **A**

REV	BY	DATE	DESCRIPTION	APPD.
A	SS	16/08/21	INITIAL DRAFT	SL

COORDINATE SYSTEM: HEIGHT DATUM: SCALE:





GENERAL NOTES  
 - 500MM VEHICLE BODY SHOWN WITH DASHED LINE  
 - DESIGN VEHICLE SWEEP PATH COMPLETED AT 10KPH  
 - ALL SWEEP PATHS COMPLETED ON SCALED AERIAL IMAGERY AND SHOULD BE VARIFIED ON SITE PRIOR TO HAULAGE OPERATIONS

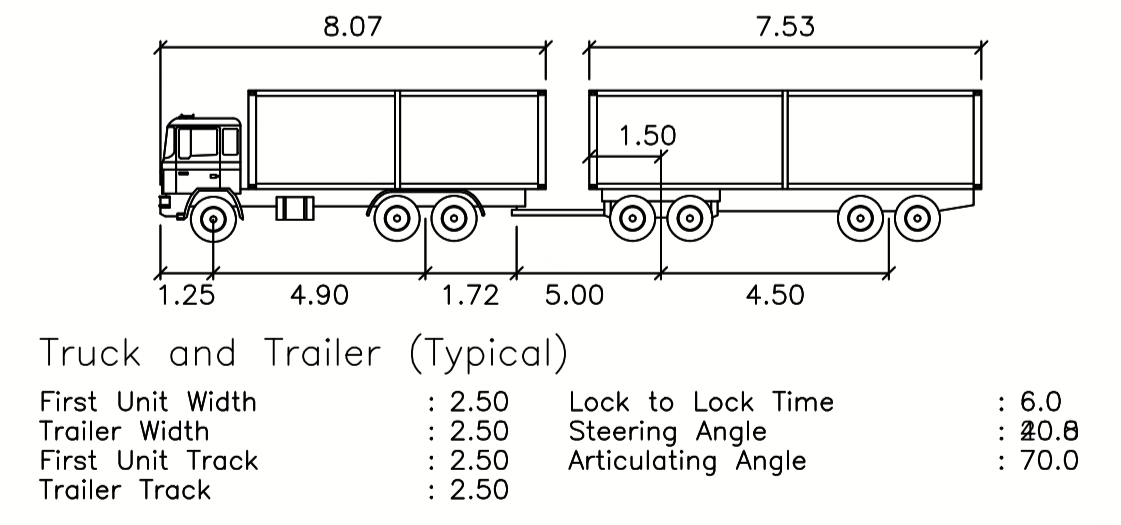
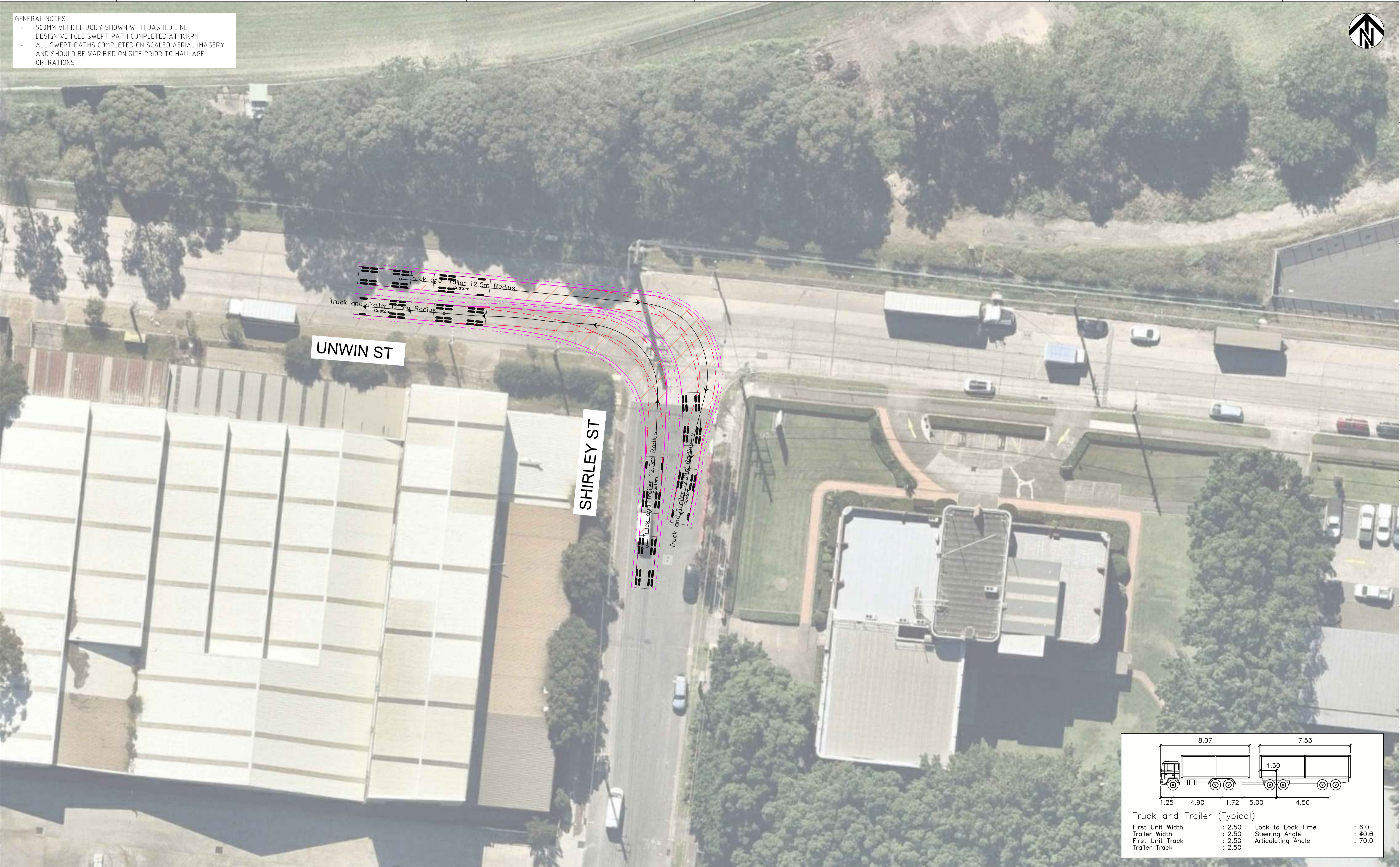

DRAWN BY: SS  
 DRW CHECK: SL  
 APPROVED: SL  
 IND REVIEW: SL

PROJECT

CLIENT



DELTA  
 CLYDE  
 SWEEP PATH ANALYSIS

DRAWING No: CLY-SPA-04-TD

SHEET 1 OF 1

REVISION A

REV	BY	DATE	DESCRIPTION	APPD.
A	SS	16/08/21	INITIAL DRAFT	SL

COORDINATE SYSTEM: HEIGHT DATUM: SCALE:



**C. Written advice**

Dear Sir/Madam,

16<sup>th</sup> September 2021

I am writing to outline my advice in relation to the local road use associated with the Clyde Demolition works, specifically the works associated with the Delta Group demolition for the Sydney Metro West project. I have worked in road design, traffic consulting and road safety auditing for many years and am currently a Level 3 Road Safety Auditor in NSW.

I've reviewed the documentation titled 'Heavy Vehicle Local Road Report' provided by the project. The Ministerial Condition of Approval (MCoA D87) specifically requires inclusion of Swept Path Analysis, Demonstration that the use of the local roads will not compromise the safety of pedestrians and cyclists or traffic flow, road dilapidation requirements and measures to avoid local road use where practical and to avoid schools, aged care facilities and childcare facilities during their peak operational times.

The proposed roads include several local roads in the industrial area of Clyde, just east of James Ruse Drive in Western Sydney. The roads in question include;

- Wentworth Street, between M4 Motorway and Duck Creek;
- Kay Street, between Wentworth Street and Unwin Street;
- Unwin Street, between Kay Street and Shirley Street; and
- Shirley Street, between Unwin Street and Duck Creek.

The swept path analysis provided demonstrates heavy vehicles can typically utilise the roads proposed without impact on opposing lanes or crowding footpaths. The swept path for a 19m semi-trailer utilising Shirley Street impacted kerb and footpath and has therefore been noted that no semi-trailers are proposed to be used to gain access/ or egress from Shirley Street.

Due to the project the area would see a significantly reduced pedestrian demand as the businesses have generally closed. The area does not contain any signs of retirement, schools or childcare facilities.

It is of note that the area, being industrial, appears to have been frequently accessed by truck and trailer combinations as evidenced by aerial imagery of the area prior to the commencement of works.

The use of the proposed local roads is expected to have limited to no adverse impact on pedestrians or impact any sensitive facilities and appear to meet the requirements outlined in MCoA D87.

Sincerely,

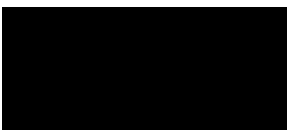

Director | Level 3 Road Safety Auditor  
Civlink Consulting Pty Ltd



## D. Road Dilapidation Report Transmittal



## Document Transmittal

<b>Transmittal No:</b>	SMWSDDS-DLT-TX-000140
<b>Contract No:</b>	EWPC - Enabling Works - 00013/13014 Parramatta and Clyde
<b>Sub Contract:</b>	-- Select a Sub Contract --
<b>Date:</b>	02 October 2021, 11:25 AM

Issued	Name
By	[Redacted] (Delta)

Issued	Name
To	[Redacted]
Cc	[Redacted]

<b>Reason for Issue</b>	
<b>Subject</b>	SM 00013/13014 Parramatta & Clyde Enabling Works Road Dilapidation Report (Parramatta, Clyde & Westmead)
<p>Dear [Redacted]</p> <p><b>Contract No. SM 00013/13014 Parramatta &amp; Clyde Enabling Works Road Dilapidation Report (Parramatta, Clyde &amp; Westmead)</b></p> <p>Please find attached for your record completed Road Dilapidation undertaken for the Parramatta, Clyde and Westmead Sites for the proposed roads to be used by Heavy Vehicles not captured in the EIS that are local roads.</p> <p>Kind Regards,</p> <p>[Redacted] Project Manager</p> <p>83 Bourke Road, Alexandria NSW 2015</p> <p>Tel. [Redacted] Mob. [Redacted] Email. [Redacted] www.deltagroup.com.au</p>	

[Click here to download all Transmittal files.](#)

Item	Document No	Title	Rev	Sts	Type	Design Lots	Alt Doc No
1	<a href="#">SMWSDDS-DLT-1NL-SR-REP-000122</a>	Road Dilapidation Report (Parramatta, Clyde & Westmead)	01.01	INF	REP		



[REDACTED]  
Director, Project Environment, Sustainability and Planning, Metro West  
Sydney Metro  
Level 43, 680 George Street  
Sydney, NSW, 2000

15/10/2021

Dear [REDACTED]

**Sydney Metro West Stage 1 (SSI-10038)  
Clyde Heavy Vehicles on Local Roads Request**

I refer to the Clyde Heavy Vehicles on Local Roads (HVL) Request which was submitted to the Planning Secretary for approval in accordance with Condition D86 of SSI 10038. I also acknowledge your response to the Department's request for information.

I note that the Clyde HVL Request:

- has been reviewed by Sydney Metro and no issues remain outstanding,
- has been prepared in consultation with Transport for NSW and City of Parramatta Council and no issues remain outstanding, and
- has been reviewed by an independent expert and the proposed use of local roads is expected to have limited to no adverse impact on pedestrians or sensitive receivers.

Accordingly, as nominee of the Planning Secretary, I approve the Clyde Heavy Vehicles on Local Roads (Revision 3, dated 5 October 2021) in accordance with Condition D86. Please ensure that the approved plan is placed on the project website at the earliest convenience.

If you wish to discuss the matter further, please contact [REDACTED] at [REDACTED].

Yours sincerely

[REDACTED]

[REDACTED]  
**Director – Infrastructure Management**

As nominee of the Planning Secretary